

Product Catalog

Water Heating and Air Conditioning Unit 2.5 to 86 kW – 50 & 60 Hz R410A Refrigerant



MORE COMFORTABLE, MORE ENERGY-SAVING

**Withair Group (China) Limited
Withair (Nanjing) Industries Co., Ltd**

Company Profile

Withair® is the premium manufacturer in sustainable energy solutions supplying HVACR products & services for heating, cooling, hot water, indoor air quality, industrial refrigeration, and heat recovery that reflect today's demand for sustainable construction, comfortable indoor climate and industrial cooling & heating process application.

Withair® specialises in innovative custom highly-configurable products designed to meet the your needs. We insure products are designed for long life by using highest quality materials, for all controls, safety, and components we only use top world-wide recognized brands. All products are rigorously tested before leaving us, going through many stages of quality control before being shipped.

The Withair System



Table of Contents

Model Nomenclature	03
Introduction	04
Flexible Design with Added Features	05
Quality Supply Chain	10
Air Conditioning and Hot Water Unit	11
A/C cooling only and hot water unit	12
A/C cooling/heating and hot water unit	13
Air Conditioning and Water Heating Unit	16
A/C cooling only and water heating unit	17
A/C cooling/heating and water heating unit	18
Domestic Heat Pump Water Heater	21
Static heating of refrigerant circulation	21
Dynamic heating of water circulation	24
Direct Heating Heat Pump Water Heater	27
Commercial Circulating Heat Pump Water Heater	33
Mini commercial circulating heat pump water heater	33
Modular commercial circulating heat pump water heater	37
Ultra-high Temperature Heat Pump Water Heater	41
Heating (Cooling) Buffer Tank	47
Domestic Water Cooler	48
Water System Installation	50
Installation Spaces	51
Engineering Guide	52
Installation Requirements	53
Unit Hoisting	54
Installation and Maintenance	55
Benefits At A Glance	56

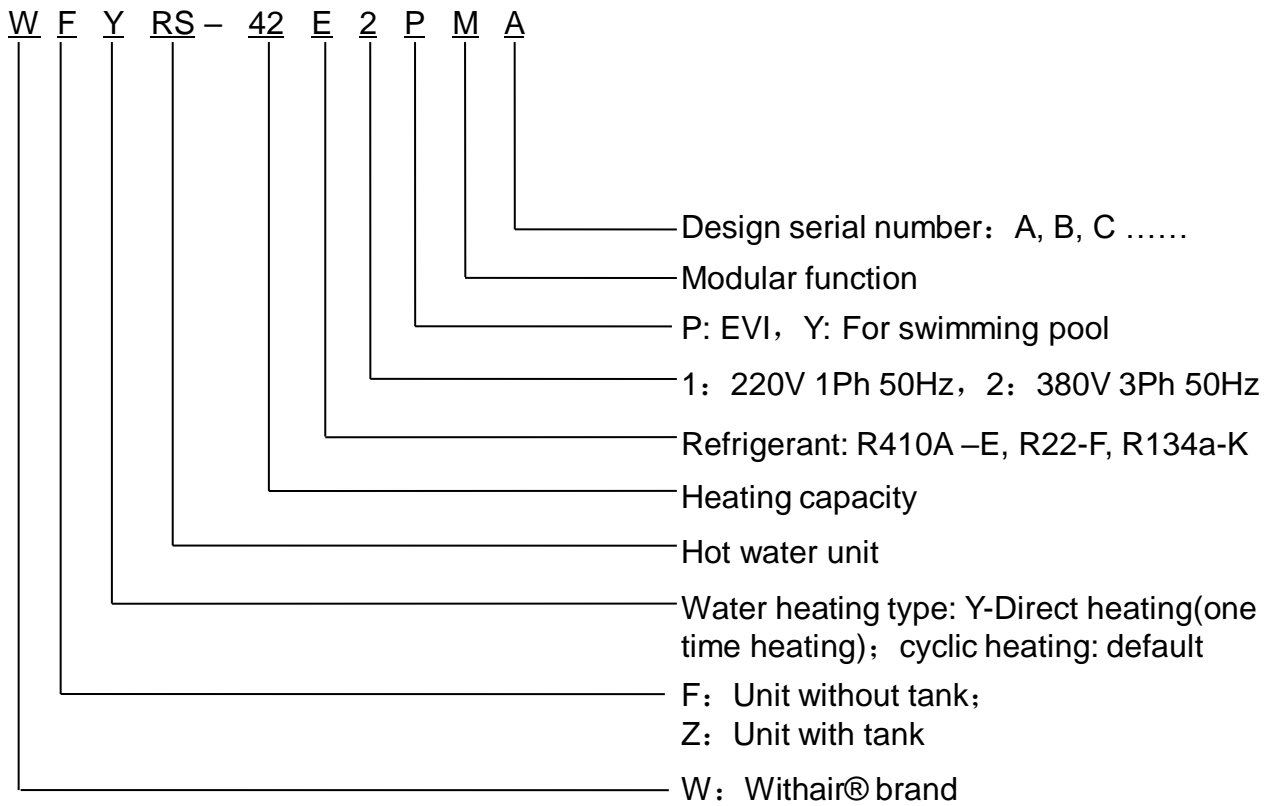

NOTE: For illustration purposes only. Not all options available with all models. Please consult your local Withair® Representative for specific availability.

AIR SOURCE HEAT PUMP WORKING PRINCIPLE

Withair® Air source heat pump unit is according to the Reverse Carnot Cycle principle, drive by a little bit of electricity, the low temperature and low-pressure refrigerant absorb a large amount of heat from air, and be vaporized, then be compressed to high temperature and high-pressure gas by compressor, enter into the water heating exchanger transferring heat into water to make hot water, then throttled by electric expansion valve and continue new cycle, a steady stream of making hot water.

The heat pump water heater is a new type of water heater product with high efficiency, energy saving, environmental protection, safety.

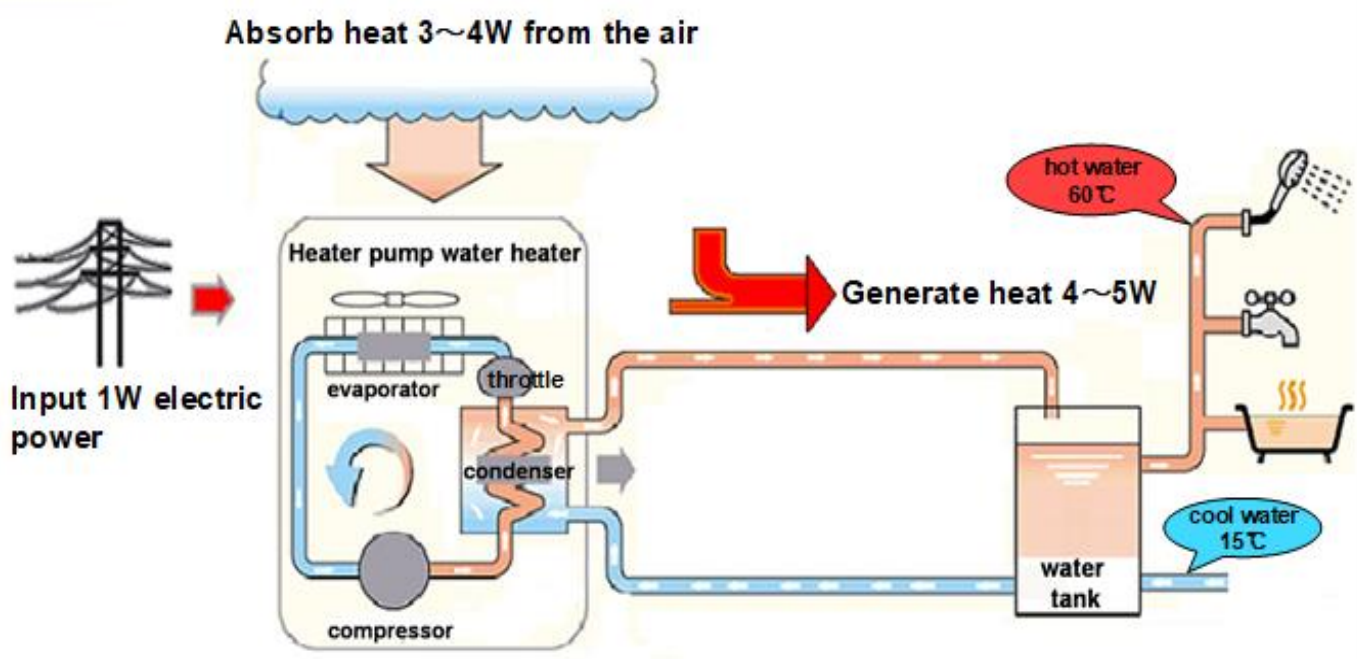

OPERATING COST SAVING

The heat generated by Withair® air source heat pump water heater is several times that of electric energy consumption. Compared with traditional electric water heater, gas water heater, the operation cost can be saved by **60% ~ 70%**, and the investment cost is easy to recover.

	Electric water heater	Gas water heater	Heat pump water heater
Energy supply	Electricity	Natural gas	Electricity
Energy calorific value	860kcal/kwh	9000kcal/m ³	860kcal/kwh
average efficiency	95%	85%	400%
Average daily energy consumption	49kwh	5.23m ³	11.6kwh
Energy prices	¥0.61	¥3.45	¥0.61
Average daily cost	¥29.9	¥18.0	¥7.1
Average annual cost	¥10901	¥6584	¥2589

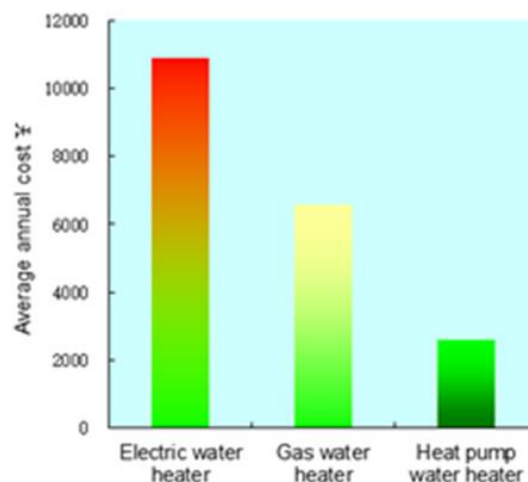

Calculation of water is 1000 kg, heating water from 15 °C to 55 °C.

EVI (ENHANCED VAPOR INJECTION) TECHNOLOGY

Withair® EVI products adopt EVI compressor and refrigerant injection system, as well as Withair® unique EVI digital control technology, effectively realize two-stage compression, obtain stronger cooling capacity, heating capacity and higher efficiency, it still has strong heating capacity at low ambient temperature.

The maximum water temperature of Withair® EVI direct heat pump water heater up to 60 °C.

Operation range of conventional products:

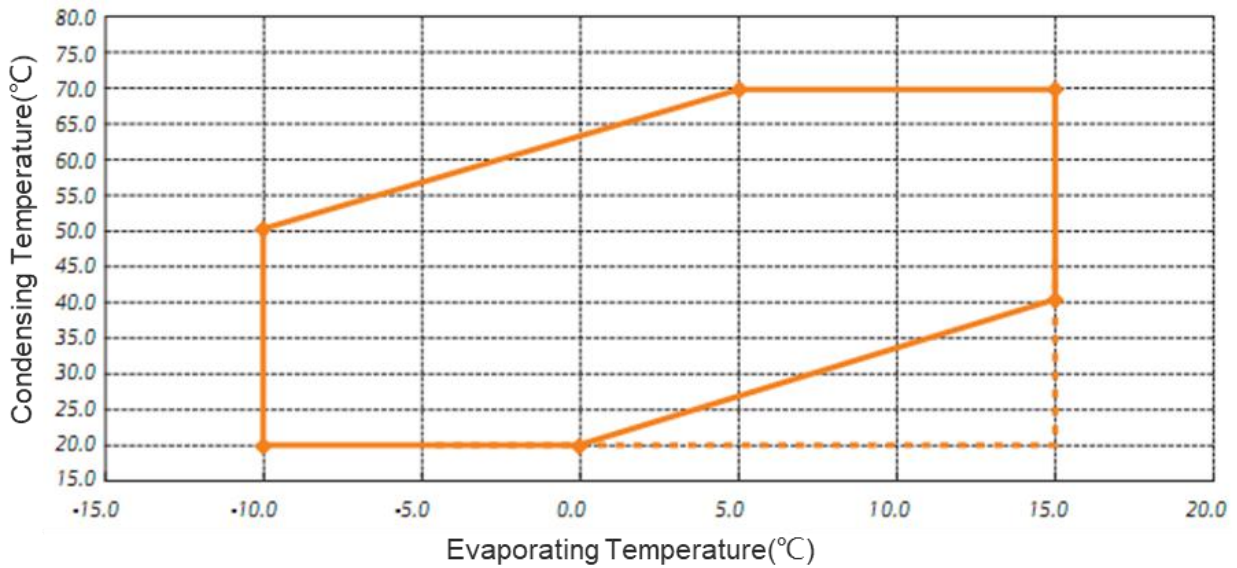

Operation range of EVI products:

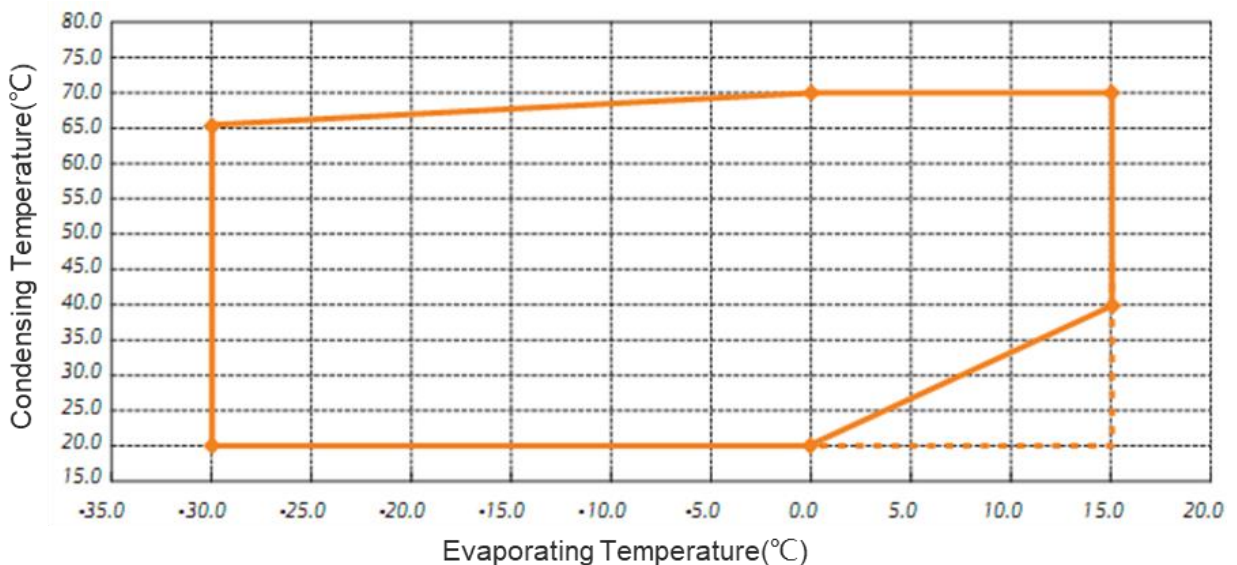

Hot water production process (single tank)

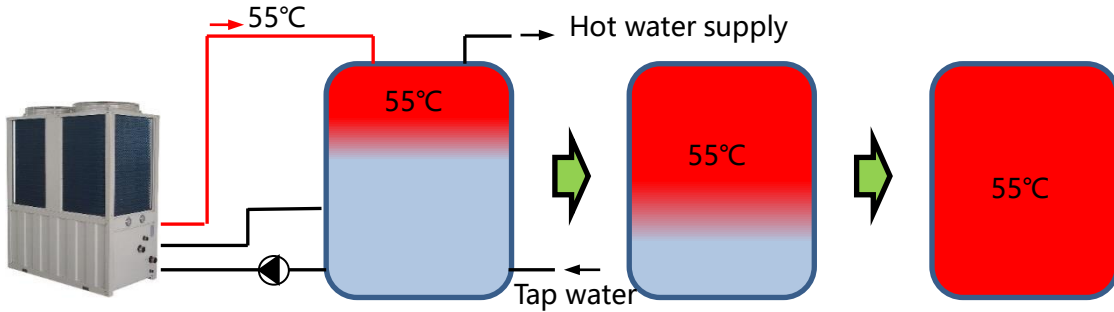

Hot water production process (multiple water tanks in series)

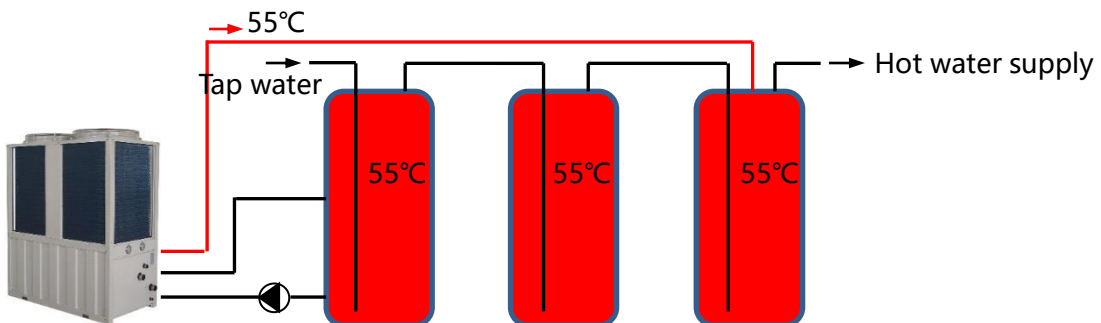
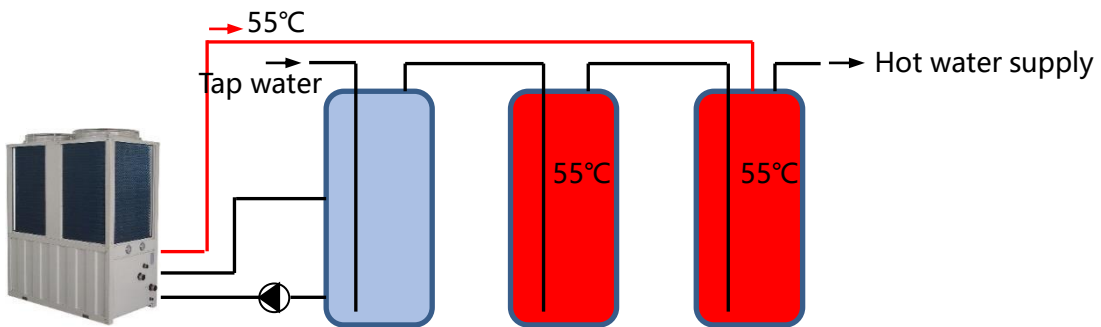
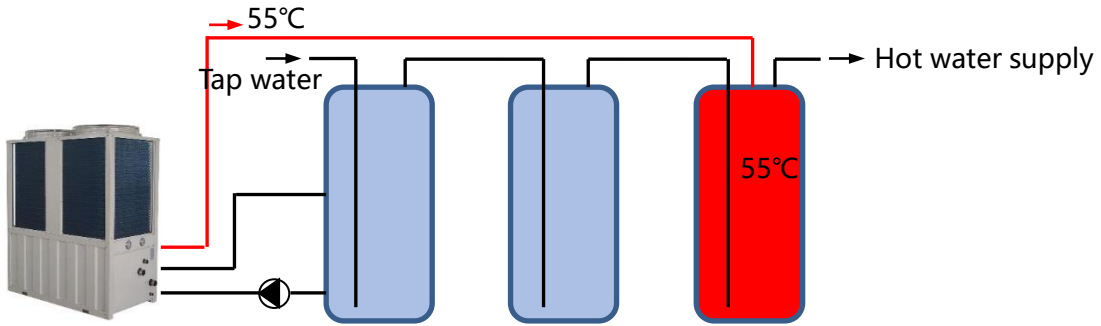

ADVANTAGES OF WITHAIR® DIRECT HEATING HOT WATER SYSTEM

- 55 °C high temperature hot water directly enters the top of the water tank and can be used for heating water at any time.
- When using hot water, tap water is added into the bottom of the water tank and is not mechanically mixed with the original hot water in the water tank. Part of the cold water is heated into 55 °C hot water by the heat pump unit for direct water supply, and the other part of the cold water pushes out the hot water from bottom to top by its own pressure in the water tank. The water supply temperature and pressure of the hot water are stable and the user is comfortable with water.
- The hot water produced by the unit can always be used immediately and effectively, which is more energy-saving and less operating cost.
- Compared with other hot water systems, the volume of water tank can be reduced by more than 30%.
- The project does not need additional heating water tank, water supply pump, water level device, solenoid valve, controller, etc. the system is simpler and more reliable.
 - When the water heater operates for defrosting in winter, the outlet water enters the lower part of the water tank, which not only has reliable defrosting operation and high efficiency, but also will not reduce the water temperature at the upper part of the water tank and affect the comfort of hot water use.
 - It is better applicable to hotels, public bathrooms, school bathhouses, foot baths, beauty salons and bodies, hospital inpatients, student dormitories, military camps, villas, etc.
 - It can be directly connected to the existing boiler system, and the original boiler system can be used as auxiliary heating.

CNC water flow regulating

The water flow regulating valve imported from Japan and digital control technology are adopted to accurately and quickly control the outlet water temperature, ensure stable hot water output and ensure the reliable operation of the unit.

Patented technology

Withair® patented direct heating technology effectively solves the defects of existing domestic hot water products, promotes the further development of heat pump hot water technology, and can be used reliably in the climate environment of -25°C ~ 46°C.

Precise defrosting

Whether in high cold and low humidity climate or low cold and high humidity climate, our digital control defrosting technology can always scientifically judge the thickness of frosting layer and the time required for defrosting. If there is no frost, it will not defrost. If there is frost, it will enter and exit defrosting in time, defrost thoroughly and do not defrost excessively, so as to improve the operation efficiency of the unit in winter.

High quality special compressor

It adopts the special compressor for heat pump of Panasonic, Hitachi and other international brands, which is suitable for high-temperature hot water and a wider ambient temperature range, with good reliability and long service life.

Tube in tube heat exchanger

The hot water side heat exchanger adopts coaxial tube in tube heat exchanger, and the inner copper pipe is of multi channel spiral design. Strong turbulence is generated when water passes through, forming flushing on the inner wall of the copper pipe, effectively improving the heat exchange efficiency, preventing scaling and avoiding the attenuation of heat exchange efficiency caused by long-term accumulation of scale.



Return water control function

This function allows users to turn on the tap to have hot water without draining a lot of cold water or waiting for a long time. The unit has two operation modes: manual water return and automatic water return. Manual water return: operate the water return key on the wire controller to return water. There are four options for automatic water return:

- Morning and evening (5:00 ~ 8:00, 17:00~23:00)
- Morning, noon and evening (5:00 ~ 8:00, 10:30~12:30, 17:00~23:00)
- 5:00 ~ 23:00
- All the day

Electronic expansion valve

The advanced digital control technology of electronic expansion valve accurately controls the flow of refrigerant, so that the unit can be in the best operation state all year round, avoids excessive load of compressor in summer and liquid hammer damage in winter, and makes the operation of the unit more stable and efficient.

Power off memory function

In case of power failure during the operation of the unit, the unit will automatically restart when the power supply is restored and continue to work according to the state before power failure.

Antifreeze function

The unit has two-stage antifreeze function, which can effectively avoid the damage of waterway freezing caused by standby or shutdown of the unit at the ambient temperature below 0°C.

Two control modes: automatic and forced. Automatic operation: when the ambient temperature is low, the water temperature is low, or the unit fails, the auxiliary electric heating will operate automatically. In order to avoid excessive use of electric heating and save energy consumption, the electric heating will stop when the water temperature reaches 50°C. Forced operation: start and stop according to the water temperature set by the water tank.

Modular combined control

Multiple units can be installed in modular combination, controlled by one wire controller, and up to 16 units form a modular combination. In the modular combination, it can also automatically judge the number of units put into operation, rest more for long operation time and work more for short operation time, so as to prolong the service life of the unit.

Protection and fault self diagnosis

In case of protection or fault during unit operation, self diagnosis, adjustment and repair will be carried out first. After repair, the unit will continue to operate and cancel the protection or fault code. If the unit cannot repair by itself, the protection or fault code will be reported all the time.

Multiple protection functions

- high voltage protection
- low voltage protection
- compressor exhaust temperature protection
- water flow protection
- inlet water temperature protection
- outlet water temperature protection
- power phase sequence and phase loss protection
- current protection

Timing function

The unit has two-stage timing function, which is convenient for users to set timing according to water consumption. There are also two kinds of timed aging: single effective, (daily) cycle effective.

Remote control / communication

- Stand-alone controls: the unit control system is equipped with remote start and stop contacts, and users can apply remote switch control according to needs.
- Building automation system (BAS) controls: equip BACnet, RS-485 communication interface with built-in Modbus communication protocol, which allows networked group control via system integration with BAS.

MAIN COMPONENTS

The main components of Withair® products are all selected famous brand products with excellent performance, so that the performance and reliability of the whole units are strongly guaranteed.

Some main components is as follows:

1. Compressors

Strong cooperation and creating high quality



2. Refrigerant accessories



3. Electric parts



AIR CONDITIONING AND HOT WATER UNIT



Product Features

01. This machine is a combination of air conditioning and heat pump water heater.
Applied range: Room cooling/heating and sanitary hot water.
02. Seven operating modes: Cooling; Heating; Hot water; Fan; Cooling + Hot water; Fan + Hot water; Heating + Hot water.
03. In summer, on the Cooling or Cooling + Hot water mode, the heat released by the outdoor unit is used to heat the water in tank, so as to get free sanitary hot water. More low carbon and energy saving.
04. Special compressor: designed especially for heat pump and hot water
05. Canned motor pump, quiet operation
06. Electronic expansion valve regulates the flow of refrigerant precisely.
07. Air-side heat exchanger: fins-coil heat exchanger with hydrophilic coating.
08. Hot water exchanger: tube in tube heat exchanger, Internal spiral design, high thermal efficiency and effective to prevent scaling.
09. Galvanized plate housing, powder coating.
10. Wireless remote control.
11. Can set the operating time freely (Two stage timing setting).
12. Intelligently and automatically judge the frosting degree and accurately defrost..
13. Automatic prevent freezing in the winter.
14. Fault diagnosis and display.
15. High pressure protection, compressor discharge temperature protection, water temperature protection, water flow protection and other multiple protection.
16. Automatic restart when power supply is restored; valley power economic operation; Economic operation when out; Auxiliary heating manual and automatic control; Operation parameter query; Control parameter query and setting; Mildew proofing of indoor unit; etc.
17. The matching water tank is free from 150L to 500L, which can be optional.

A/C COOLING ONLY AND HOT WATER UNIT

R410A — 220V ~ 240V 50Hz

Model	Whole machine model		WF-RS-25E1GW	WF-RS-25E1GWA	WF-RS-32E1GW	WF-RS-32E1GWA
	Outdoor unit model		WF-RS-25E1W	WF-RS-25E1WA	WF-RS-32E1W	WF-RS-32E1WA
	Indoor unit model		WF-RS-25E1G	WF-RS-25E1G	WF-RS-32E1G	WF-RS-32E1G
Power supply			220-240V 50Hz 1Ph			
Working mode			AC cooling; Hot water; Fan; AC Cooling + Hot water; Fan+Hot water			
A/C Cooling +Hot water	Cooling capacity	W	2500	2500	3200	3200
	Heat recovery capacity for hot water	W	2800	2800	3600	3600
	Rated power input	W	815	815	1046	1046
	COP	W/W	6.5	6.5	6.5	6.5
	Rated hot water output	L/h	80	80	102	102
Hot water	Heating capacity	W	3500	3500	4500	4500
	Rated power input	W	900	900	1155	1155
	COP	W/W	3.9	3.9	3.9	3.9
	Rated hot water output	L/h	100	100	128	128
	Hot water temperature	℃	20~60	20~60	20~60	20~60
A/C Cooling	Cooling capacity	W	2500	2500	3200	3200
	Rated power input	W	760	760	970	970
	EER	W/W	3.29	3.29	3.3	3.3
Refrigerant			R410A			
Max water temperature		℃	≥ 60			
Outdoor unit						
Water flow(Hot water heating)		m ³ /h	Water pump is Internally installed			
Noise		dB(A)	54	54	54	54
Net/Gross weight		kg	48/52	48/52	52/56	52/56
Unit dimensions(L×W×H)		mm	850×290×605			
Packing dimensions(L×W×H)		mm	975×385×650			
Water pipe connector		mm	G3/4"			
Ambient condition		℃	-10~46	8~46	-10~46	8~46
Indoor unit						
Air flow		m ³ /h	600	600	650	650
Noise		dB(A)	39	39	41	41
Net/Gross weight		kg	8.9/10.7	8.9/10.7	9.9/11.7	9.9/11.7
Unit dimensions(L×W×H)		mm	825×290×195		900×290×195	
Packing dimensions(L×W×H)		mm	885×360×280		1030×360×280	
Water tank(optional)						
Matching tank model			SX150,SX200,SX300; SX500			

The data in the following table are tested under rated conditions as follows:

1. A/C cooling +Hot water: Outdoor temperature (DB/WB): 35℃/24℃; Indoor temperature (DB/WB): 27℃/19℃; Hot water: heating water from 25℃ to 55℃;
2. Hot water: Ambient temperature (DB/WB): 20℃/15℃, heating water from 15℃ to 55℃;
3. A/C cooling: Outdoor temperature (DB/WB): 35℃/24℃; Indoor temperature (DB/WB): 27℃/19℃;
4. All specifications are subject to change without prior notice, please refer to the nameplate.

A/C COOLING & HEATING AND HOT WATER UNIT

R410A — 220V ~ 240V 50Hz

Model	Whole machine model		WFR-RS-25E1GW	WFRd-RS-25E1GW	WFR-RS-32E1GW	WFRd-RS-32E1GW
	Outdoor unit model		WFR-RS-25E1W	WFRd-RS-25E1W	WFR-RS-32E1W	WFRd-RS-32E1W
	Indoor unit model		WFR-RS-25E1G	WFRd-RS-25E1G	WFR-RS-32E1G	WFRd-RS-32E1G
Power supply			220-240V 50Hz 1Ph			
Working mode			AC cooling; AC heating; Hot water; Fan; AC cooling + Hot water; Fan+Hot water; AC heating+Hot water			
A/C cooling+ Hot water	Cooling capacity	W	2500	2500	3200	3200
	Heat recovery capacity for hot water	W	2800	2800	3600	3600
	Rated power input	W	815	815	1046	1046
	COP	W/W	6.5	6.5	6.5	6.5
	Rated hot water output	L/h	80	80	102	102
Hot water	Heating capacity	W	3500	3500	4500	4500
	Rated power input	W	900	900	1155	1155
	COP	W/W	3.9	3.9	3.9	3.9
	Rated hot water output	L/h	100	100	128	128
	Hot water temperature	°C	20~60	20~60	20~60	20~60
A/C cooling	Cooling capacity	W	2500	2500	3200	3200
	Rated power input	W	760	760	970	970
	EER	W/W	3.29	3.29	3.3	3.3
A/C heating	Heating capacity	W	2750	2750(3550)	3500	3500(4300)
	Rated power input	W	764	764(1564)	972	972(1772)
	COP	W/W	3.6	3.6	3.6	3.6
	Electric heater power	W	/	800	/	800
Refrigerant			R410A			
Max water temperature		°C	≥60			
Outdoor unit						
Water flow(Hot water heating)		m ³ /h	Water pump is Internally installed			
Noise		dB(A)	54	54	54	54
Net/Gross weight		kg	48/52	52/56	52/56	52/56
Unit dimensions(L×W×H)		mm	850×290×605			
Packing dimensions(L×W×H)		mm	975×385×650			
Water pipe connector		mm	G3/4"			
Ambient condition		°C	-10~46			
Indoor unit						
Air flow		m ³ /h	600	600	650	650
Noise		dB(A)	39	39	41	41
Electric heater power		W	/	800	/	800
Net/Gross weight		kg	8.9/10.7	8.9/10.7	9.9/11.7	9.9/11.7
Unit dimensions(L×W×H)		mm	825×290×195		900×290×195	
Packing dimensions(L×W×H)		mm	885×360×280		1030×360×280	
Water tank(optional)						
Matching tank model			SX150,SX200,SX300; SX500			

The data in the following table are tested under rated conditions as follows:

1. A/C cooling +Hot water: Outdoor temperature (DB/WB): 35°C/24°C; Indoor temperature (DB/WB): 27°C/19°C; Hot water: heating water from 25°C to 55°C;
2. Hot water: Ambient temperature (DB/WB): 20°C/15°C, heating water from 15°C to 55°C;
3. A/C cooling: Outdoor temperature (DB/WB): 35°C/24°C; Indoor temperature (DB/WB): 27°C/19°C;
4. A/C heating: Outdoor temperature (DB/WB): 7°C/6°C; Indoor temperature (DB/WB): 20°C/15°C;
5. All specifications are subject to change without prior notice, please refer to the nameplate.

BUFFER TANK

Tank model		SX150	SX200	SX300	SX500
Volume	L	150	200	300	500
Cold/hot water pipe connector	mm	G1/2"	G1/2"	G3/4"	G3/4"
Circulating water pipe connector	mm	G3/4"	G3/4"	G3/4"	G3/4"
Drain connector	mm	G1/2"			
Net/Gross weight	kg	30/34	35/41	53/60	77/86
Unit dimension (D×H)	mm	Ø480×1385	Ø520×1535	Ø580×1782	Ø700×1893
Packing dimension (L×W×H)	mm	545×545×1531	595×595×1628	635×635×1847	780×780×1955
Inner tank material		Stainless steel 304			
Insulation thickness	mm	50			
Out case		Color galvanized steel sheet			

SCHEMATIC DIAGRAM

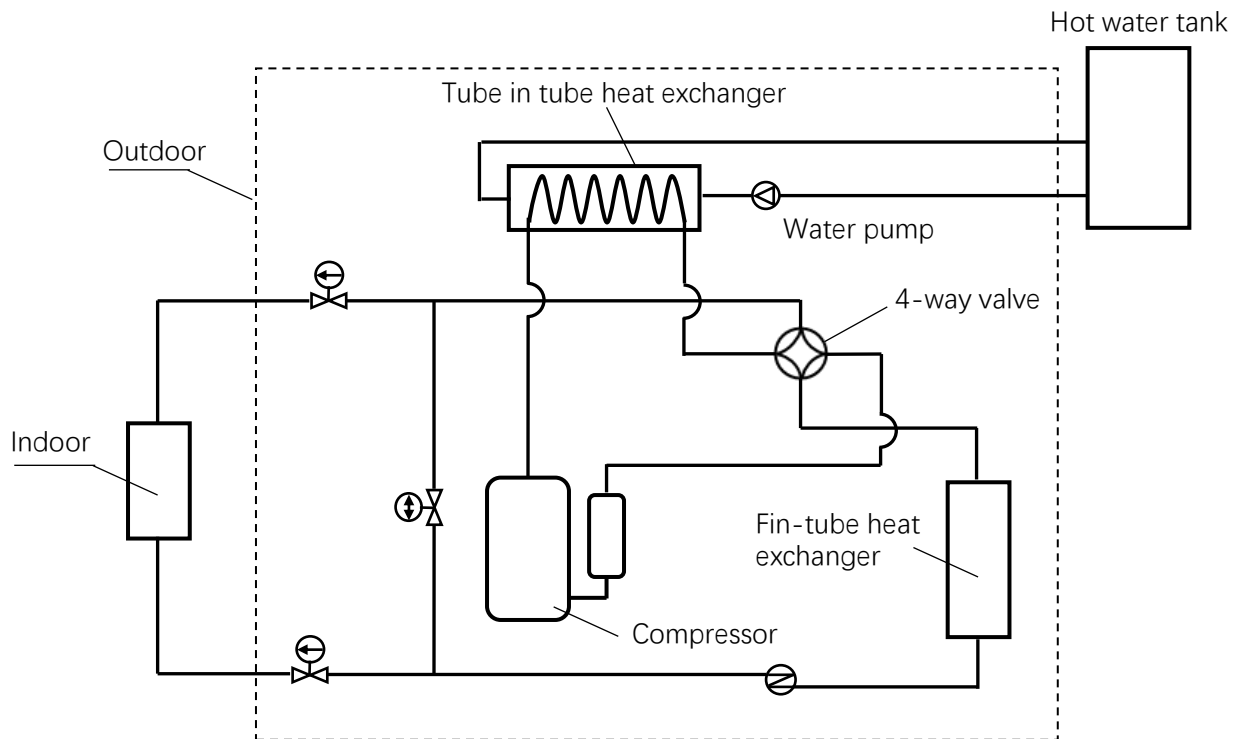

The Application Diagram

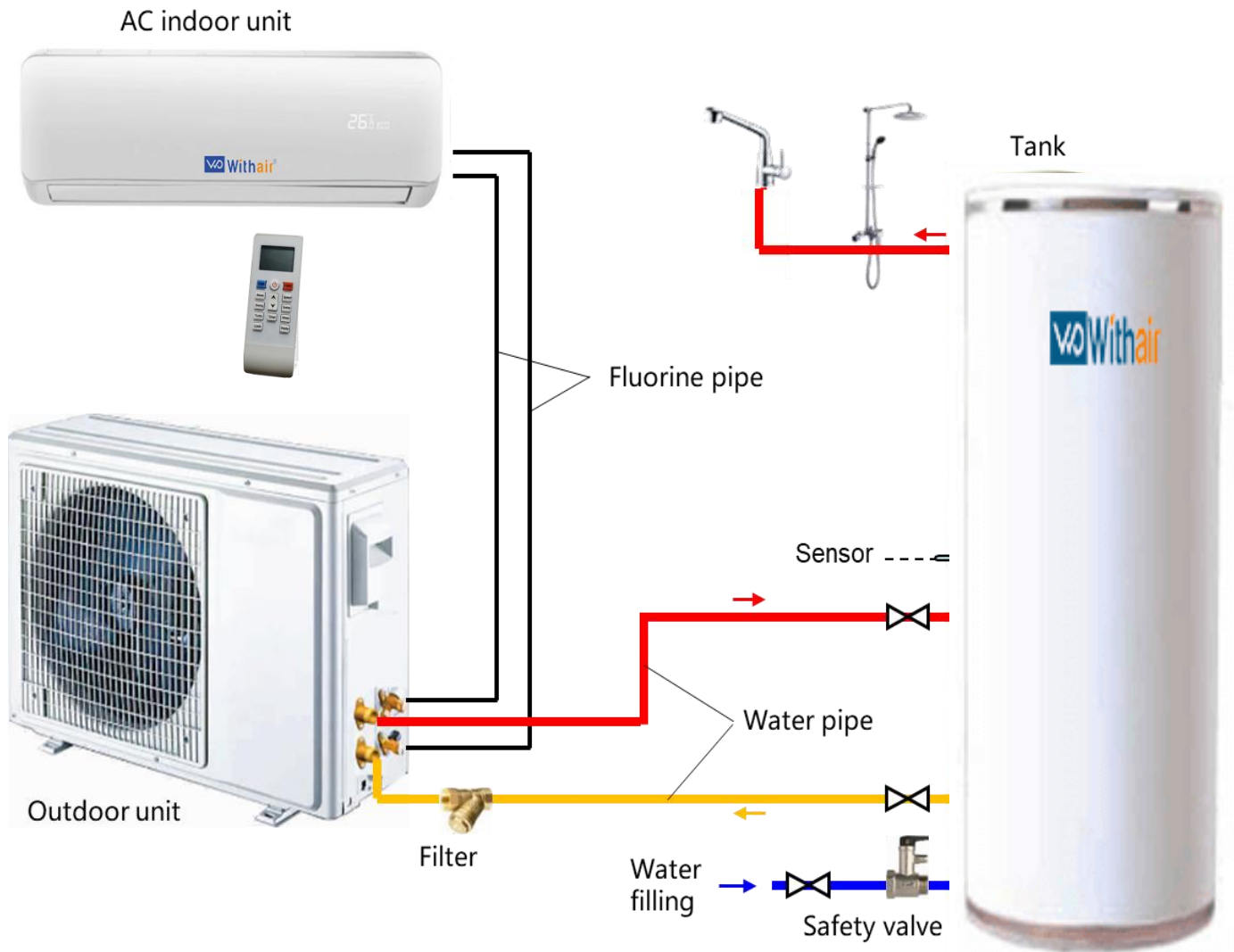

A/C COOLING ONLY AND WATER HEATING UNIT



Product Features

01. Applied range: Room AC cooling/heating and Floor water heating or radiator water heating.
02. Working modes: AC cooling; AC heating; Water heating.
03. Special compressor: designed especially for heat pump and water heating.
04. Electronic expansion valve regulates the flow of refrigerant precisely.
05. Air-side heat exchanger: fins-coil heat exchanger with hydrophilic coating.
06. Water heating exchanger: tube in tube heat exchanger, Internal spiral design, high thermal efficiency and effective to prevent scaling.
07. Canned motor pump, quiet operation.
08. Galvanized plate housing, powder coating.
09. Wireless remote control.
10. Can set the operating time freely (Two stage timing setting).
11. Intelligently and automatically judge the frosting degree and accurately defrost.
12. Automatic prevent freezing in the winter.
13. Fault diagnosis and display.
14. High pressure protection, compressor discharge temperature protection, water temperature protection, water flow protection and other multiple protection.
15. Automatic restart when power supply is restored; Economic operation when out; Auxiliary heating manual and automatic control; Operation parameter query; Control parameter query and setting; Mildew proofing of indoor unit; etc.

A/C COOLING & HEATING AND HOT WATER UNIT

R410A — 220V ~ 240V 50Hz

Model	Whole machine model		WF-SN-25E1GW	WF-SNd-25E1GW	WF-SN-32E1GW	WF-SNd-32E1GW
	Outdoor unit model		WF-SN-25E1W	WF-SNd-25E1W	WF-SN-32E1W	WF-SNd-32E1W
	Indoor unit model		WF-RS-25E1G	WF-RS-25E1G	WF-RS-32E1G	WF-RS-32E1G
Power supply			220-240V 50Hz 1Ph			
Refrigerant			R410A			
Working mode			AC cooling; Water heating			
A/C cooling	Cooling capacity	W	2500	2500	3200	3200
	Rated power input	W	760	760	970	970
	EER	W/W	3.29	3.29	3.3	3.3
Water heating	Heating capacity	W	3200	3200(4200)	4000	4000(5000)
	Rated power input	W	1000	1000(2000)	1195	1195(2195)
	COP	W/W	3.19	3.19	3.35	3.35
	Electric heater power	W	/	1000	/	1000
	Max outlet water temp	°C	55	55	55	55
Floor heating area	m ²		32~40	42~52	40~50	50~62
Radiator heating area	m ²		16~20	21~26	20~25	25~31
Outdoor unit						
Water flow(Hot water heating)	m ³ /h		Water pump is installed			
Noise	dB(A)		54	54	54	54
Electric heater power	W		/	1000	/	1000
Net/Gross weight	kg		48/52	48/52	52/56	52/56
Unit dimensions(L×W×H)	mm		850×290×605			
Packing dimensions(L×W×H)	mm		975×385×650			
Water pipe connector	mm		G3/4"			
Ambient condition	Radiator heating	°C	-10~46	-10~46	-10~46	-10~46
	Floor heating	°C	-10~46	-15~46	-10~46	-15~46
Indoor unit						
Air flow	m ³ /h		600	600	650	650
Noise	dB(A)		39	39	41	41
Net/Gross weight	kg		8.9/10.7	8.9/10.7	9.9/11.7	9.9/11.7
Unit dimensions(L×W×H)	mm		825×290×195		900×290×195	

The data in the following table are tested under rated conditions as follows:

1. A/C cooling: Outdoor temperature (DB/WB): 35°C/24°C; Indoor temperature (DB/WB): 27°C/19°C;
2. Water heating: Ambient temperature (DB/WB): 7°C/6°C, outlet water temperature: 45°C;
3. Total power including water pump;
4. All specifications are subject to change without prior notice, please refer to the nameplate.

A/C COOLING & HEATING AND WATER HEATING UNIT

R410A — 220V ~ 240V 50Hz

Model	Whole machine model		WFR-SN-25E1GW	WFR-SNd-25E1GW	WFR-SN-32E1GW	WFR-SNd-32E1GW
	Outdoor unit model		WFR-SN-25E1W	WFR-SNd-25E1W	WFR-SN-32E1W	WFR-SNd-32E1W
	Indoor unit model		WFR-RS-25E1G	WFR-RS-25E1G	WFR-RS-32E1G	WFR-RS-32E1G
Power supply			220-240V 50Hz 1Ph			
Refrigerant			R410A			
Working mode			AC cooling; Water heating; AC heating			
A/C cooling	Cooling capacity	W	2500	2500	3200	3200
	Rated power input	W	760	760	970	970
	EER	W/W	3.29	3.29	3.3	3.3
A/C heating	Heating capacity	W	2750	2750	3500	3500
	Rated power input	W	764	764	972	972
	COP	W/W	3.6	3.6	3.6	3.6
Water heating	Heating capacity	W	3200	3200(4200)	4000	4000(5000)
	Rated power input	W	1000	1000(2000)	1195	1195(2195)
	COP	W/W	3.19	3.19	3.35	3.35
	Electric heater power	W	/	1000	/	1000
	Max outlet water temp	°C	55	55	55	55
Floor heating area	m ²		32 ~ 40	42 ~ 52	40 ~ 50	50 ~ 62
Radiator heating area	m ²		16 ~ 20	21 ~ 26	20 ~ 25	25 ~ 31
Outdoor unit						
Water flow(Hot water heating)	m ³ /h		Water pump is installed			
Noise	dB(A)		54	54	54	54
Electric heater power	W		/	1000	/	1000
Net/Gross weight	kg		48/52	48/52	52/56	52/56
Unit dimensions (L×W×H)	mm		850×290×605			
Packing dimensions (L×W×H)	mm		975×385×650			
Water pipe connector	mm		G3/4"			
Ambient condition	Radiator heating	°C	-10 ~ 46	-10 ~ 46	-10 ~ 46	-10 ~ 46
	Floor heating	°C	-10 ~ 46	-15 ~ 46	-10 ~ 46	-15 ~ 46
Indoor unit						
Air flow	m ³ /h		600	600	650	650
Noise	dB(A)		39	39	41	41
Net/Gross weight	kg		8.9/10.7	8.9/10.7	9.9/11.7	9.9/11.7
Unit dimensions (L×W×H)	mm		825×290×195		900×290×195	

- The data in the following table are tested under rated conditions as follows:
1. A/C cooling: Outdoor temperature (DB/WB): 35°C/24°C; Indoor temperature (DB/WB): 27°C/19°C;
 2. A/C heating: Outdoor temperature (DB/WB): 7°C/6°C; Indoor temperature (DB/WB): 20°C/15°C;
 3. Water heating: Ambient temperature (DB/WB): 7°C/6°C, outlet water temperature: 45°C;
 4. Total power including water pump;
 5. All specifications are subject to change without prior notice, please refer to the nameplate.

BUFFER TANK

Tank model		SN40
Volume	L	40
Circulating water pipe connector	mm	G3/4"
Drain connector	mm	G1/2"
Unit dimension (D×H)	mm	Ø420×585

The Application Diagram

Diagram 1 — Water Supply Type 1

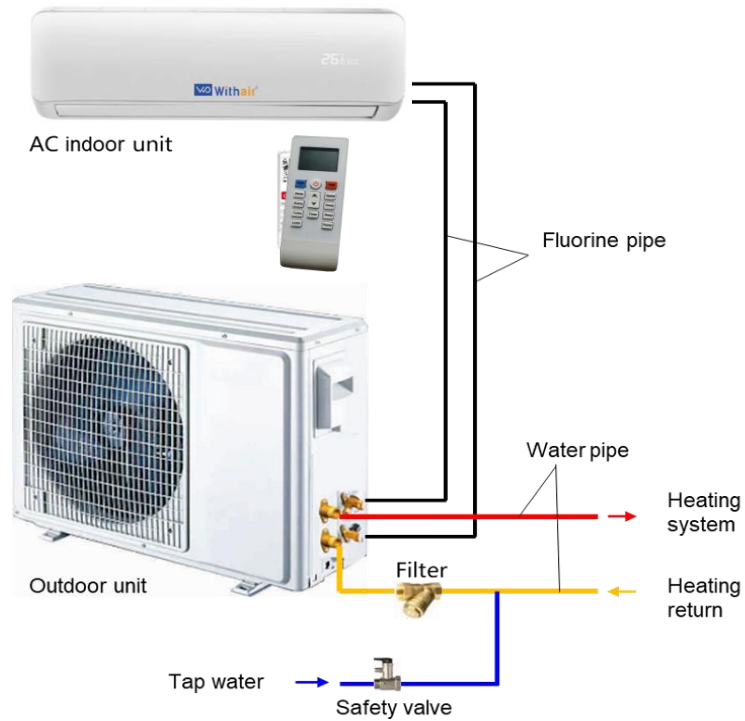

Diagram 2 — Water Supply Type 2

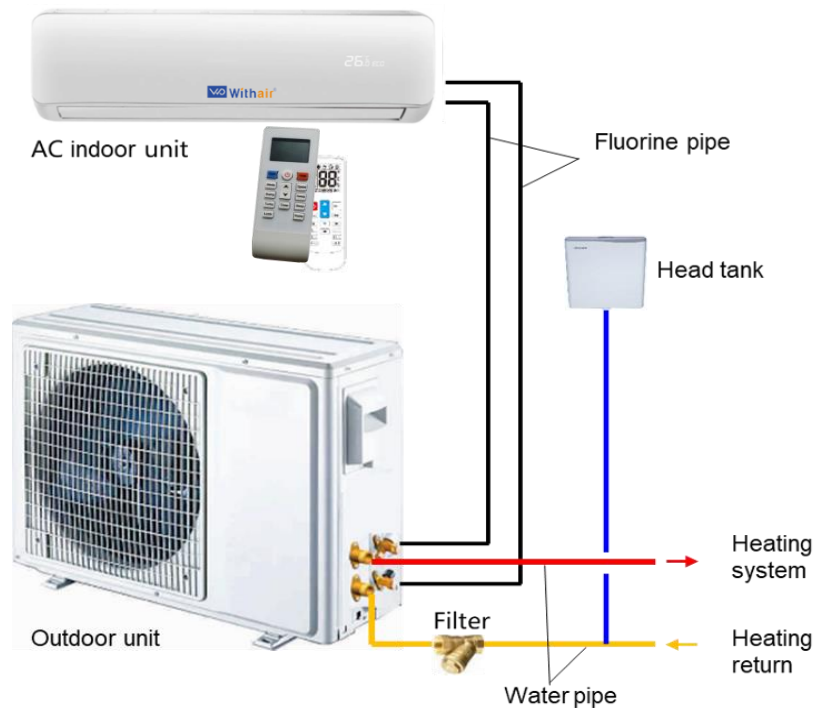

Diagram 3 — Application System 1

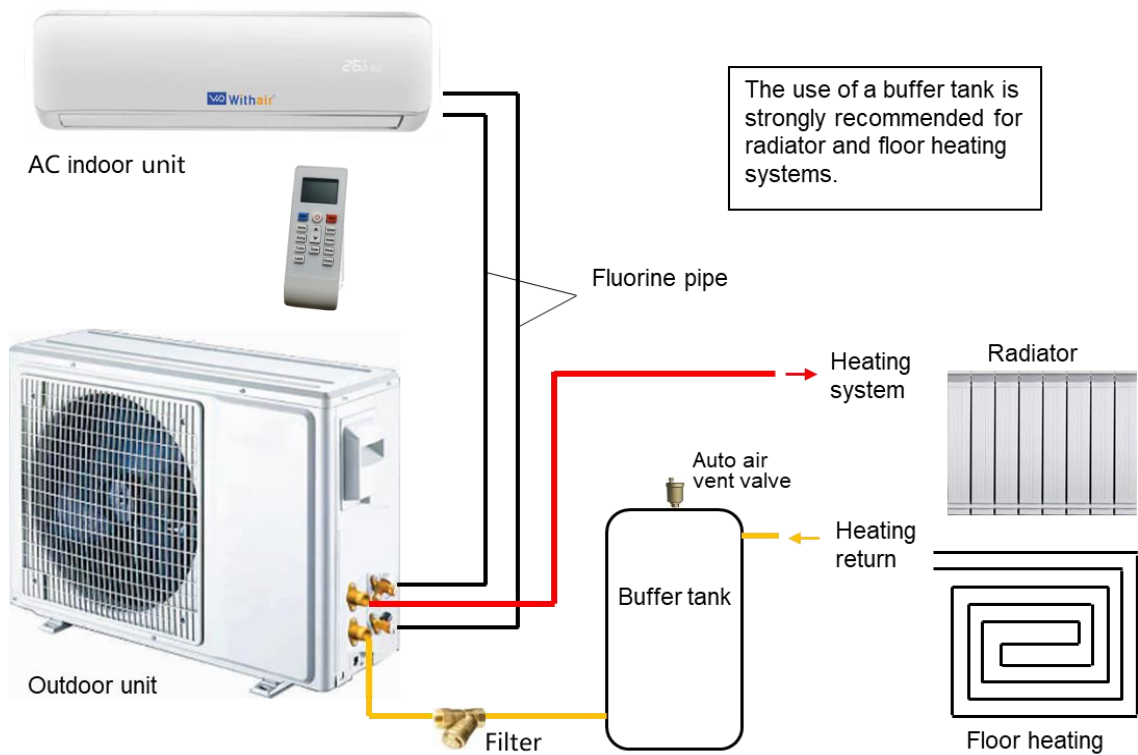
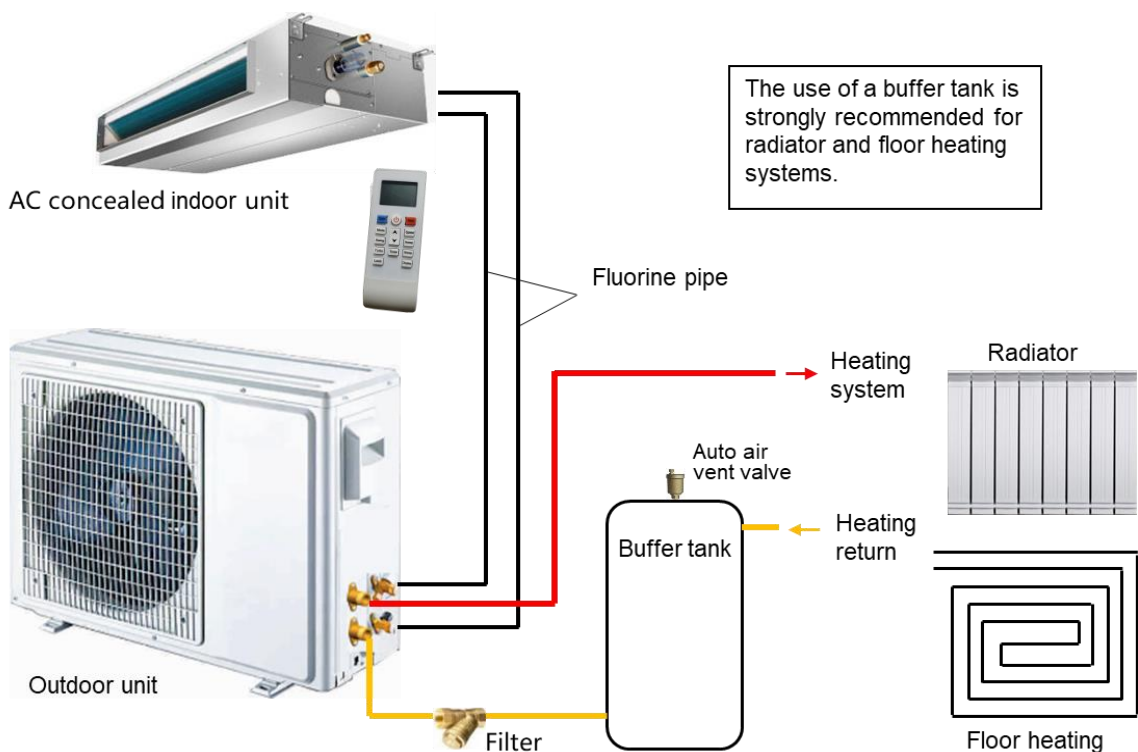

Diagram 4 — Application System 2



STATIC HEATING OF REFRIGERANT CIRCULATION



Product Features

01. Applied range: household sanitary hot water, maximum water temperature 60°C.
02. Special compressor: specially designed for heat pump water heater.
03. Electric expansion valve regulates the flow of refrigerant precisely.
04. Air exchanger(Fins-coil) with hydrophilic coating.
05. LCD display wire controller.
06. Can set the operating time freely(Two stage timing setting).
07. Unit runs or stop automatically according to water temperature.
08. Intelligently and automatically judge the frosting degree and accurately defrost.
09. Automatic prevent tank freezing in the winter.
10. Failure diagnosis and display.
11. With control of auxiliary heating device(e.g. electric heating) is optional.
12. High pressure protection, compressor discharge temperature protection, water temperature protection, water flow protection and other multiple protection.
13. Automatic restart when power supply is restored; Valley power economic operation; Economic operation when out; Auxiliary heating manual and automatic control; Operation parameter query; Control parameter query and setting; etc.
14. Water tank:
 - The inner tank material is stainless steel 304.
 - The heating water exchanger is installed in inner tank, high heat exchange efficiency. The material of heat exchange coil is food grade stainless steel 316L.
 - Insulation layer is 50mm.
 - The water tank is specially designed with low working pressure and long service life.
 - Auxiliary electric heater is optional.



HEAT PUMP MODEL AND SPECIFICATION

R410A — 220V ~ 240V 50Hz

Outdoor unit model		WFRS-3.6E1W	WFRS-3.6E1WA	WFRSd-3.6E1W	WFRS-4.6E1W	WFRS-4.6E1WA	WFRSd-4.6E1W
Power supply (V / Hz / Ph)		220-240 / 50 / 1			220-240 / 50 / 1		
Refrigerant		R410A			R410A		
Heating capacity	kW	3.6			4.6		
Rated power input	kW	0.845			1.1		
COP	W/W	4.26			4.19		
Rated hot water output	L/h	77			98		
Water temperature range	°C	20~60			20~60		
Noise	dB(A)	50			53		
Net/Gross weight	kg	28/32			32/37		
Unit dimensions (L×W×H)	mm	700×255×545			760×255×545		
Packing dimensions (L×W×H)	mm	825×300×640			885×300×640		
With control for auxiliary electric heater		/	/	Yes	/	/	Yes
Ambient condition	°C	-10~52	7~52	-15~52	-10~52	7~52	-15~52
Matching tank model		FX150-1, FX200-1		FXd150-1 FXd200-1	FX300-2, FX500-2		FXd300-2 FXd500-2
Main accessories		Connecting pipe(Ø9.52/Ø6.35mm), Power line,Safety valve,etc					

The data in the following table are tested under rated conditions as follows:

1. Heating test conditions: ambient air dry bulb temperature 20°C, wet bulb temperature 15°C;
2. Entering water temperature 15°C, leaving water temperature 55°C;
3. All specifications are subject to change without prior notice, please refer to the nameplate.

Water Tank Specification

Tank model		FX150-1	FXd150-1	FX200-1	FXd200-1	FX300-2	FXd300-2	FX500-2	FXd500-2
Volume	L	150		200		300		500	
Auxiliary electric heater power	W	/	1500	/	1500	/	2000	/	2000
Cold/hot water pipe connector	mm	G1/2"		G1/2"		G3/4"		G3/4"	
Drain connector	mm	G1/2"							
Fluorine pipe connector	in	5/8",7/16"		5/8",7/16"		5/8",7/16"		5/8",7/16"	
Net/Gross weight	kg	31/35		36/42		54/61		80/89	
Unit dimensions (D×H)	mm	Ø480×1385		Ø520×1535		Ø580×1782		Ø700×1893	
Packing dimensions (L×W×H)	mm	545×545×1531		595×595×1628		635×635×1847		780×780×1955	

THE APPLICATION DIAGRAM

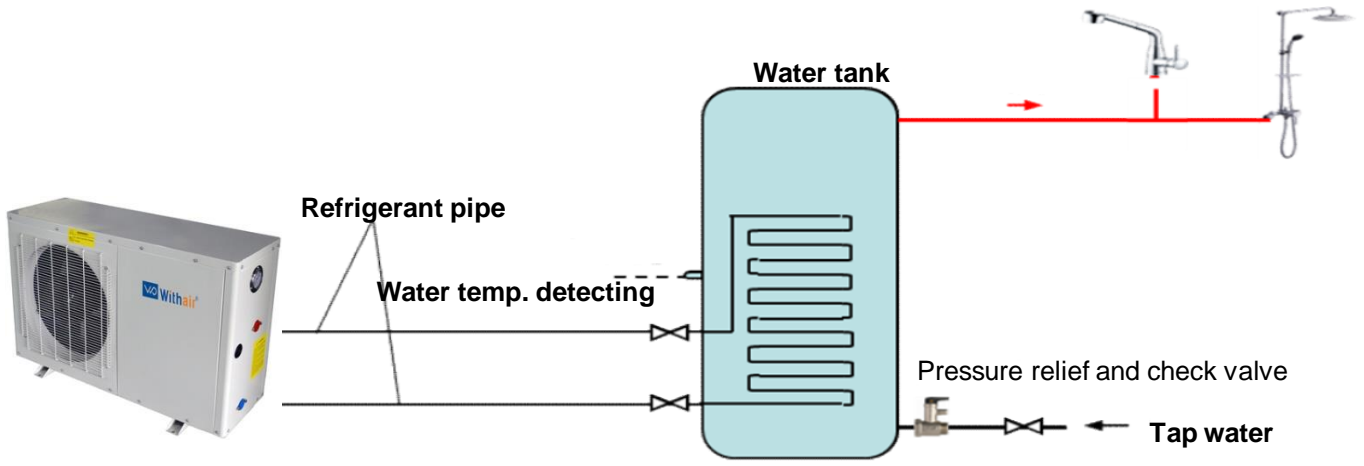

DYNAMIC HEATING OF WATER CIRCULATION



Product Features

01. Applied range: household sanitary hot water, floor heating.
maximum outlet water temperature 60°C.
02. Special compressor: specially designed for heat pump water heater.
03. Electric expansion valve regulates the flow of refrigerant precisely.
04. Air exchanger (Fins-coil) with hydrophilic coating.
05. Water pump and water heating exchanger are internally installed.
06. Water exchanger: Coaxial tube in tube heat exchanger. Internal several spiral flute corrugated structure, eddy current and concave turbulent flow scouring, with the descaling ability, ensure tube clean, so higher heat exchange efficiency, stable performance.
07. LCD display wire controller.
08. Can set the operating time freely(Two stage timing setting).
09. Unit runs or stop automatically according to water temperature.
10. Intelligently and automatically judge the frosting degree and accurately defrost.
11. Automatic prevent freezing in the winter.
12. Failure diagnosis and display.
13. Auxiliary electric heater is optional.
14. High pressure protection, compressor discharge temperature protection, water temperature protection, water flow protection and other multiple protection.
15. Automatic restart when power supply is restored; Valley power economic operation;
Economic operation when out; Auxiliary heating manual and automatic control;
Operation parameter query; Control parameter query and setting; etc.
16. Water tank: tank from 100L to 500L can be matched freely.

HEAT PUMP MODEL AND SPECIFICATION

R410A — 220V ~ 240V 50Hz

Model		WFRS-4.6E1	WFRS-4.6E1A	WFRSd-4.6E1	WFRS-6.8E1	WFRS-6.8E1A	WFRSd-6.8E1
Power supply (V / Hz / Ph)		220-240 / 50 / 1			220-240 / 50 / 1		
Refrigerant		R410A			R410A		
Heating capacity	kW	4.6			6.8		
Rated power input	kW	1.14			1.68		
COP	W/W	4.05			4.05		
Rated hot water output	L/h	98			145		
Max outlet water temp of heat pump	°C	65			65		
Water temperature range	°C	20~60			20~60		
Noise	dB(A)	54			55		
Net/Gross weight	kg	52/56			56/60		
Unit dimension (L×W×H)	mm	850×290×605			850×290×605		
Packing dimension (L×W×H)	mm	975×385×650			975×385×650		
Water pipe connector	mm	G3/4"			G3/4"		
Auxiliary electric heater power	W	/	/	1000	/	/	1000
Ambient condition	°C	-10~52	7~52	-15~52	-10~52	7~52	-15~52
Matching tank volume	L	150~500			300~1000		

The data in the following table are tested under rated conditions as follows:

1. Heating test conditions: ambient air dry bulb temperature 20°C, wet bulb temperature 15°C;
2. Entering water temperature 15°C, leaving water temperature 55°C;
3. All specifications are subject to change without prior notice, please refer to the nameplate.

Water Tank Specification

Tank model		SX150	SX200	SX300	SX500	SX1000
Volume	L	150	200	300	500	1000
Cold/hot water pipe connector	mm	G1/2"	G1/2"	G3/4"	G3/4"	G1"
Circulating inlet/outlet connector	mm	G3/4"	G3/4"	G3/4"	G1"	G1"
Direct heating connector	mm	/	/	/	G3/4"	G3/4"
Drain connector	mm	G1/2"				
Net/Gross weight	kg	30/34	35/41	53/60	77/86	136/150
Unit dimension (D×H)	mm	Ø480×1385	Ø520×1535	Ø580×1782	Ø700×1893	Ø900×2115
Packing dimension (L×W×H)	mm	545×545×1531	595×595×1628	635×635×1847	780×780×1955	980×980×2180
Inner tank material		Stainless steel 304				
Insulation thickness	mm	50				
Out case		Color galvanized steel sheet				

THE APPLICATION DIAGRAM

Diagram 1 — Hot water system

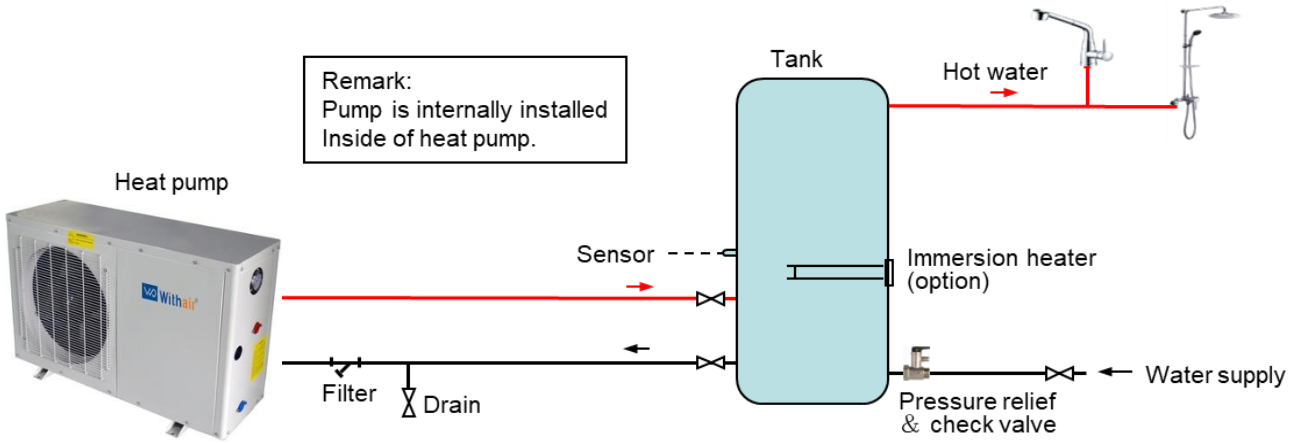

Diagram 2—Hot water system (with heating coil in tank)

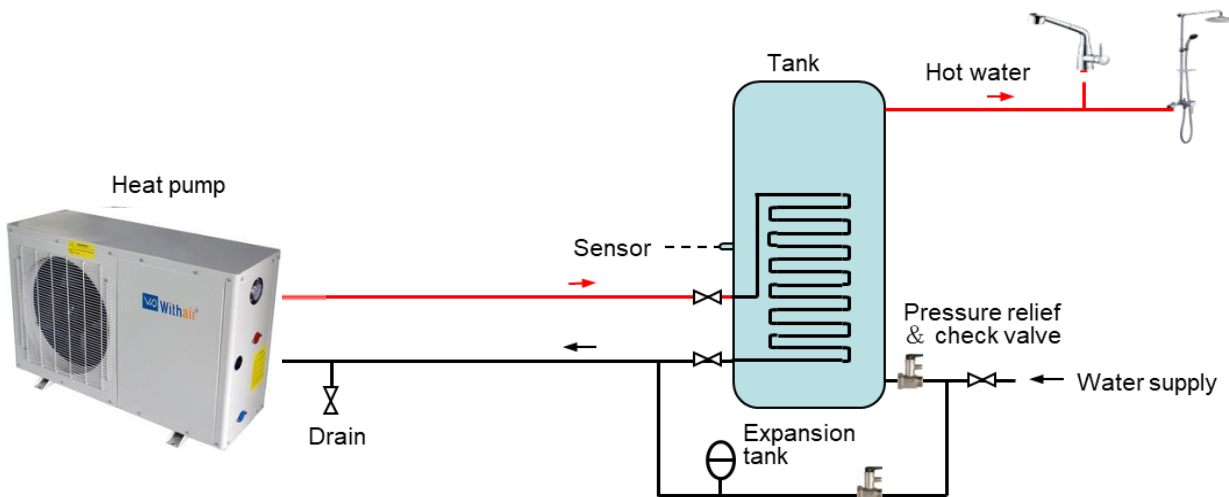
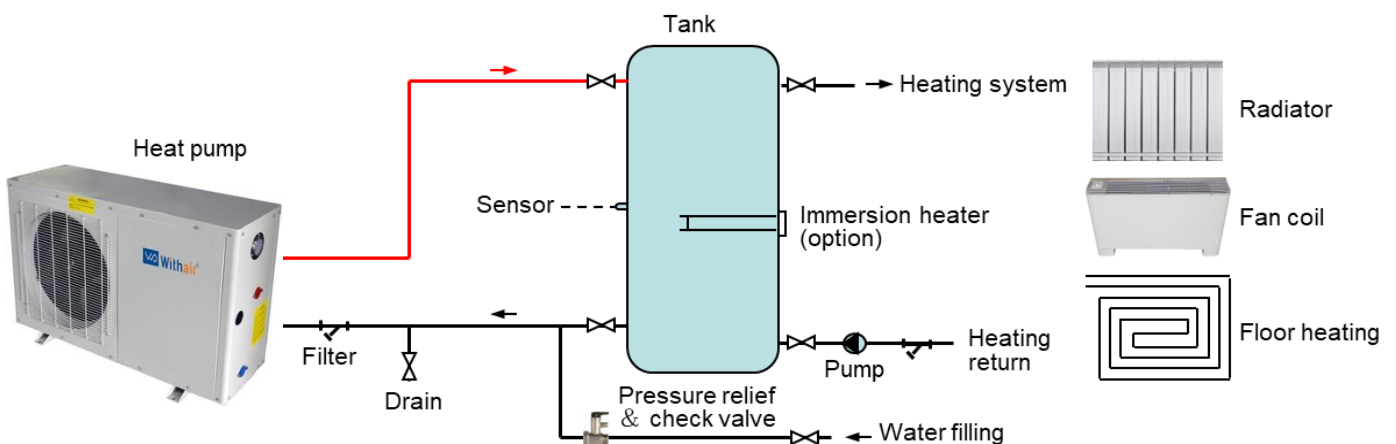

Diagram 3—Room heating system



DIRECT HEATING HEAT PUMP WATER HEATER



Product Features

01. Applied range: sanitary hot water for bathhouse, hotel, salon, villa, etc.
02. Direct heating type: The cold water is heated to 55°C at one time. When the hot water is in use or the water tank temperature is low, the machine runs in direct heating mode. When the water tank temperature is high, the machine runs in circulating heating mode. Compared with the circulating system, stable water supply temperature, the hot water utilization rate of the direct heating system is higher, the volume of the water tank can be reduced by more than 30%.
03. Special heat pump compressor.
04. Electronic expansion valve regulates the flow of refrigerant precisely.
05. Water exchanger: tube in tube heat exchanger, Internal spiral design, high thermal efficiency and effective to prevent scaling. Air exchanger with hydrophilic coating.
06. Galvanized plate housing, powder coating.
07. LCD display wire controller, Fault diagnosis and display.
08. Modular control design: units installing combine freely, one controller can control maximum 16 pcs units, and the quantity of running compressors will be auto adjusted according to water temperature changing.
09. Soft start design: compressors start or stop in sequence, first start the one with longer rest.
10. Can set the operating time freely (Two stage timing setting).
11. Unit runs or stop automatically according to tank water temperature.
12. Intelligent automatic defrosting. Automatic prevent freezing in the winter.
13. With control of auxiliary heating device (e.g. electric heating).
14. High pressure protection, Low pressure protection, compressor discharge temperature protection, water temperature protection, water flow protection, Power phase sequence protection, and other multiple protection.
15. Automatic restart when power supply is restored; Auxiliary heating manual and automatic control; Operation parameter query; Control parameter query and setting; etc.
16. BACnet, RS485 and Modbus communication function as option.

HEAT PUMP MODEL AND SPECIFICATION

R410A — 220V/380V 50Hz

Model		WFYRS-11E1M	WFYRS-20E2M	WFYRS-42E2M
Power supply (V / Hz / Ph)		220~240/50/1	380~415/50/3	
Refrigerant		R410A	R410A	
Heating capacity	kW	12	20	42
Rated power input	kW	2.76	4.6	9.66
COP	W/W	4.35	4.35	4.35
Rated hot water output	L/h	235	428	900
Direct heating outlet water temp	°C	55	55	
Max tank water temperature	°C	55	55	
Circulating water flow	m ³ /h	2.1	3.8	7.9
Noise	dB(A)	57	58	65
Water pipe connector	mm	G1"	G1"	G1-1/2"
Ambient condition	°C	-10~46	-10~46	
Net/Gross weight	kg	95/103	126/134	300/320
Unit dimensions(L×W×H)	mm	1160×510×1430	1160×510×1430	1445×740×1650

The data in the following table are tested under rated conditions as follows:

1. Heating test conditions: ambient air dry bulb temperature 20°C, wet bulb temperature 15°C;
2. Entering water temperature 15°C, leaving water temperature 55°C;
3. All specifications are subject to change without prior notice, please refer to the nameplate.

EVI R410A — 220V/380V 50Hz

Model		WFYRS-12E1PM	WFYRS-22E2PM	WFYRS-45E2PM
Power supply (V / Hz / Ph)		220~240/50/1	380~415/50/3	
Refrigerant		R410A	R410A	
Heating capacity	kW	13	22	45
Rated power input	kW	2.79	4.77	9.68
COP	W/W	4.66	4.61	4.65
Rated hot water output	L/h	257	470	960
Heating capacity(-12°C)	kW	6.24	11.44	23.4
COP(-12°C)	W/W	2.52	2.58	2.6
Heating capacity(-20°C)	kW	5.16	9.46	19.35
COP(-20°C)	W/W	2.16	2.21	2.23
Direct heating outlet water temp	°C	55	55	
Max tank water temperature	°C	60	60	
Circulating water flow	m ³ /h	2.3	4.1	8.5
Noise	dB(A)	57	59	65
Water pipe connector	mm	G1"	G1"	G1-1/2"
Ambient condition	°C	-25~46	-25~46	
Net/Gross weight	kg	100/108	131/139	300/320
Unit dimensions(L×W×H)	mm	1160×510×1430	1160×510×1430	1445×740×1650

The data in the following table are tested under rated conditions as follows:

1. Heating test conditions: ambient air dry bulb temperature 20°C, wet bulb temperature 15°C;
2. Entering water temperature 15°C, leaving water temperature 55°C;
3. All specifications are subject to change without prior notice, please refer to the nameplate.

HEAT PUMP MODEL AND SPECIFICATION

R410A — 380V/3Ph/60Hz

Model		WFYRS-20E4M	WFYRS-42E4M
Power supply (V / Hz / Ph)		380/60/3	
Refrigerant		R410A	
Heating capacity	kW	20	42
Rated power input	kW	4.6	9.66
COP	W/W	4.35	4.35
Rated hot water output	L/h	428	900
Direct heating outlet water temp	°C	55	
Max tank water temperature	°C	55	
Circulating water flow	m ³ /h	3.8	7.9
Noise	dB(A)	58	65
Water pipe connector	mm	G1"	G1-1/2"
Ambient condition	°C	-10~46	
Net/Gross weight	kg	126/134	300/320
Unit dimensions(L×W×H)	mm	1160×510×1430	1445×740×1650

The data in the following table are tested under rated conditions as follows:

1. Heating test conditions: ambient air dry bulb temperature 20°C, wet bulb temperature 15°C;
2. Entering water temperature 15°C, leaving water temperature 55°C;
3. All specifications are subject to change without prior notice, please refer to the nameplate.

EVI R410A — 380V/3Ph/60Hz

Model		WFYRS-20E4PM	WFYRS-42E4PM
Power supply (V / Hz / Ph)		380/60/3	
Refrigerant		R410A	
Heating capacity	kW	20	42
Rated power input	kW	4.34	9
COP	W/W	4.61	4.65
Rated hot water output	L/h	428	900
Heating capacity(-12°C)	kW	10.4	21.84
COP(-12°C)	W/W	2.58	2.6
Heating capacity(-20°C)	kW	8.6	18.1
COP(-20°C)	W/W	2.21	2.23
Direct heating outlet water temp	°C	55	
Max tank water temperature	°C	60	
Circulating water flow	m ³ /h	3.8	7.9
Noise	dB(A)	58	65
Water pipe connector	mm	G1"	G1-1/2"
Ambient condition	°C	-25~46	
Net/Gross weight	kg	131/139	300/320
Unit dimensions(L×W×H)	mm	1160×510×1430	1445×740×1650

The data in the following table are tested under rated conditions as follows:

1. Heating test conditions: ambient air dry bulb temperature 20°C, wet bulb temperature 15°C;
2. Entering water temperature 15°C, leaving water temperature 55°C;
3. All specifications are subject to change without prior notice, please refer to the nameplate.

PROJECT CONNECTING WATER TANK

Tank model		Main water tank		Auxiliary water tank
		SX500	SXd500	SX500A
Volume	L	500	500	500
Auxiliary electric heater	W	/	6000+6000	/
Cold/hot water pipe connector	mm	G1-1/2"	G1-1/2"	G1-1/2"
Direct heating inlet connector (Pressure relief connector)	mm	G1"	G1"	G1"
Circulating inlet/outlet connector	mm	G1-1/2"	G1-1/2"	/
Drain connector	mm	G1/2"		
Net/Gross weight	kg	77/86	77/86	77/86
Unit dimensions (D×H)	mm	Ø700×1893	Ø700×1893	Ø700×1893

ENGINEERING APPLICATION DIAGRAM

Diagram 1 — Hot water system

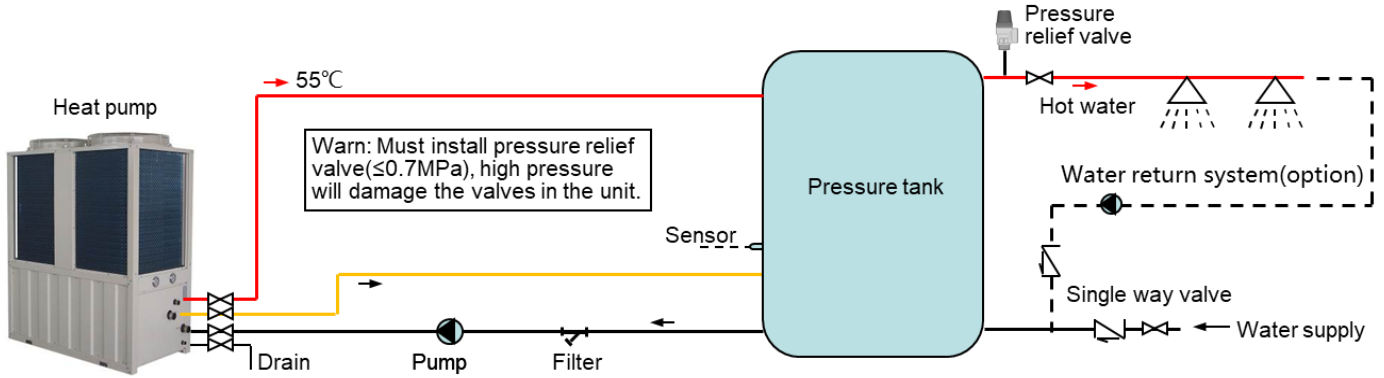

Diagram 2 — Hot water system(with auxiliary heater)

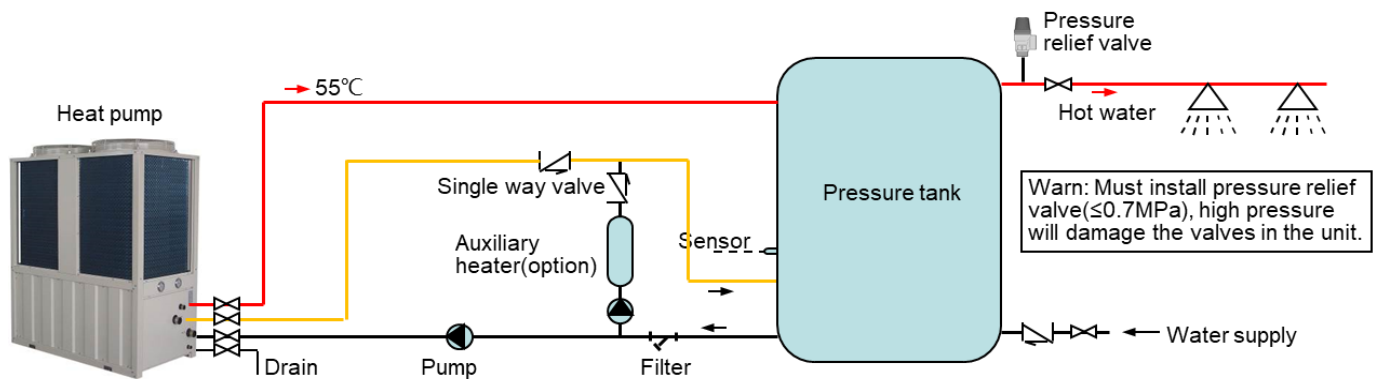
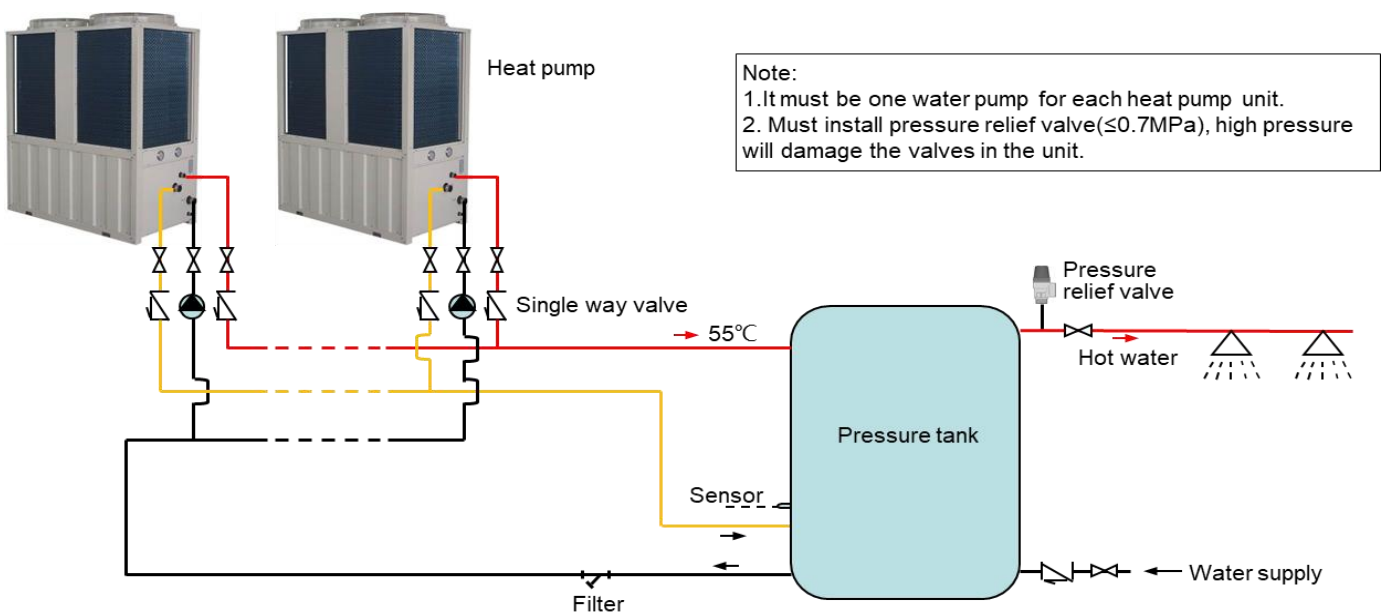

Diagram 3 — Modular hot water system



ENGINEERING APPLICATION DIAGRAM

Diagram 4 — Hot water system with series tanks

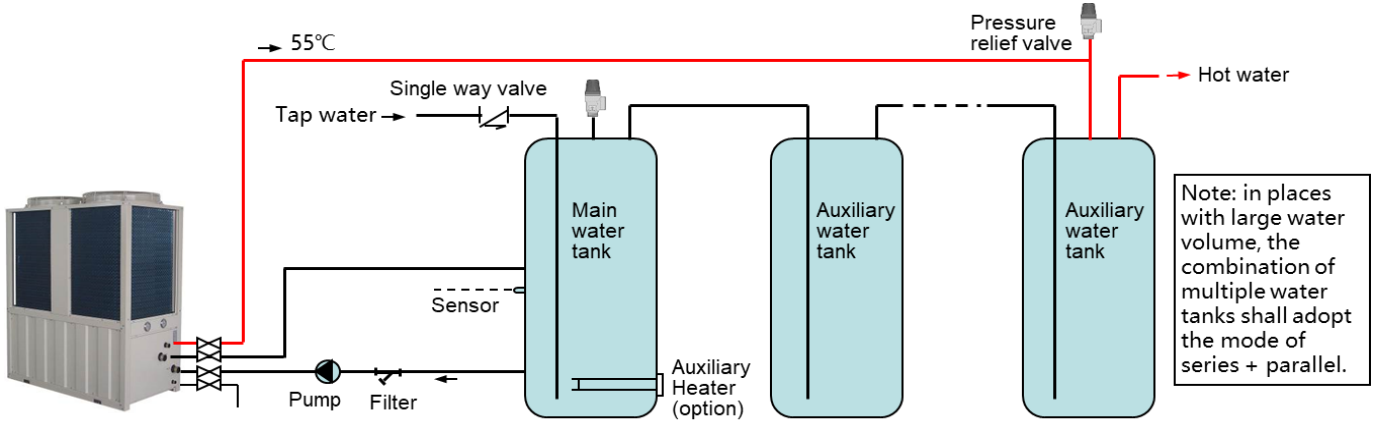
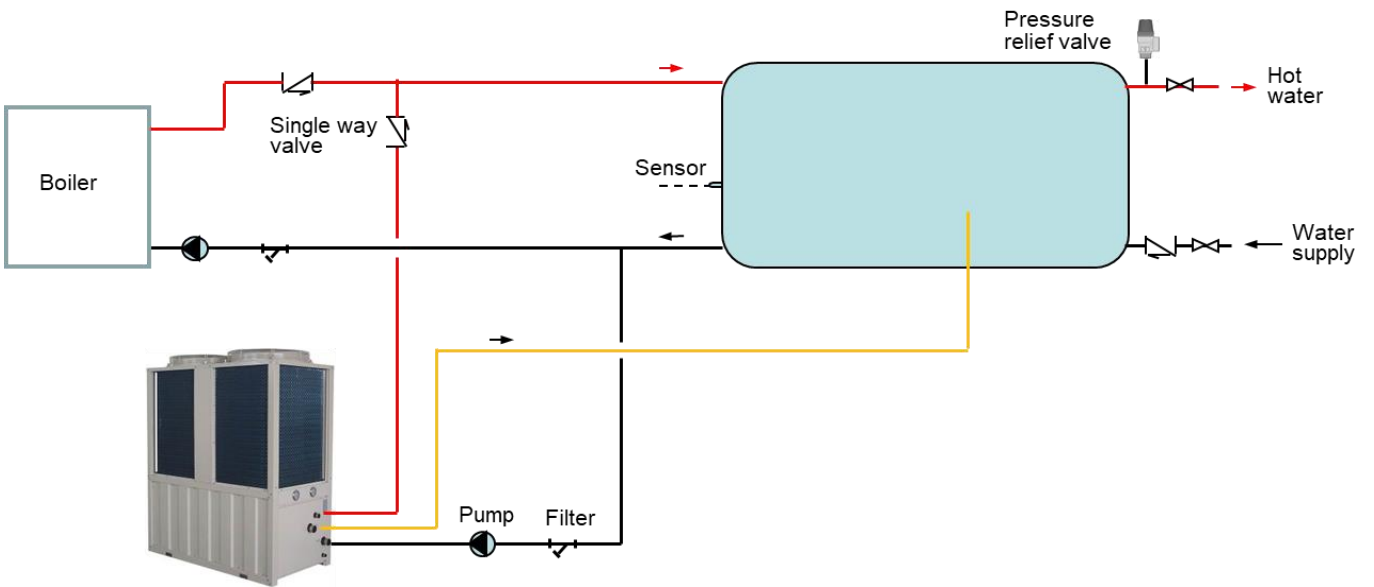

Diagram 5 — Connected to the original boiler hot water system



MINI COMMERCIAL CIRCULATING HEAT PUMP WATER HEATER



Product Features

01. Applied range: sanitary hot water; floor heating, radiator heating, fan coil heating.
02. Special heat pump compressor.
03. Electronic expansion valve regulates the flow of refrigerant precisely.
04. Air exchanger (Fins-coil) with hydrophilic coating.
05. Water exchanger: tube in tube heat exchanger, Internal spiral design, high thermal efficiency and effective to prevent scaling.
06. Galvanized plate housing, powder coating.
07. LCD display wire controller.
08. With hot water return control to keep the water warm in supplying pipe.
09. Can set the operating time freely (Two stage timing setting).
10. Unit runs or stop automatically according to tank water temperature.
11. Intelligently and automatically judge the frosting degree and accurately defrost.
12. Automatic prevent freezing in the winter.
13. With control of auxiliary heating device (e.g. electric heating).
14. Fault diagnosis and display.
15. High pressure protection, Low pressure protection, compressor discharge temperature protection, water temperature protection, water flow protection, Power phase sequence protection, and other multiple protection.
16. Automatic restart when power supply is restored; Auxiliary heating manual and automatic control; Operation parameter query; Control parameter query and setting; etc.
17. RS485 and Modbus communication function.
18. BACnet, RS485 and Modbus communication function as option.

HEAT PUMP MODEL AND SPECIFICATION

R410A — 220 ~ 240V / 380 ~ 415V 50Hz

Model		WFRS-11E1	WFRS-18E1	WFRS-20E2
Power supply (V / Hz / Ph)		220~240/50/1		380~415/50/3
Refrigerant		R410A		
Heating capacity	kW	11	18	20
Rated power input	kW	2.51	4	4.4
COP	W/W	4.38	4.50	4.55
Rated hot water output	L/h	235	386	428
Max outlet water temp of heat pump	°C	60	60	60
Max tank water temperature	°C	55	55	55
Circulating water flow	m³/h	2.1	3.4	3.8
Noise	dB(A)	57	58	58
Water pipe connector	mm	G1"		G1"
Ambient condition	°C	-10~46		
Net/Gross weight	kg	94/102	125/133	125/133
Unit dimensions(L×W×H)	mm	1160×510×1430		

The data in the following table are tested under rated conditions as follows:

1. Heating test conditions: ambient air dry bulb temperature 20°C, wet bulb temperature 15°C;
2. Entering water temperature 15°C, leaving water temperature 55°C;
3. All specifications are subject to change without prior notice, please refer to the nameplate.

EVI R410A — 220 ~ 240V / 380 ~ 415V 50Hz

Model		WFRS-12E1P	WFRS-18E1P	WFRS-22E1P	WFRS-22E2P
Power supply (V / Hz / Ph)		220/50/1			380/50/3
Refrigerant		R410A			R410A
Heating capacity	kW	12	18	22	22
Rated power input	kW	2.67	4.1	4.58	4.54
COP	W/W	4.50	4.39	4.80	4.85
Rated hot water output	L/h	257	386	471	471
Heating capacity(-12°C)	kW	6.24	9.36	11.44	11.44
COP(-12°C)	W/W	2.52	2.46	2.69	2.72
Heating capacity(-20°C)	kW	5.16	7.74	9.46	9.46
COP(-20°C)	W/W	2.16	2.11	2.3	2.33
Max outlet water temp of heat pump	°C	65	65	65	65
Max tank water temperature	°C	60	60	60	60
Circulating water flow	m³/h	2.3	3.4	4.1	4.1
Noise	dB(A)	57	58	59	59
Water pipe connector	mm	G1"			G1"
Ambient condition	°C	-25~46			
Net/Gross weight	kg	99/107	130/138	130/138	130/138
Unit dimensions(L×W×H)	mm	1160×510×1430			

The data in the following table are tested under rated conditions as follows:

1. Heating test conditions: ambient air dry bulb temperature 20°C, wet bulb temperature 15°C;
2. Entering water temperature 15°C, leaving water temperature 55°C;
3. All specifications are subject to change without prior notice, please refer to the nameplate.

HEAT PUMP MODEL AND SPECIFICATION

R410A — 220-240V / 380 ~ 415V 60Hz

Model		WFRS-12E3	WFRS-20E3	WFRS-20E4
Power supply (V / Hz / Ph)		208~230/60/1		380/60/3
Refrigerant		R410A		
Heating capacity	kW	12	20	20
Rated power input	kW	2.74	4.4	4.4
COP	W/W	4.38	4.55	4.55
Rated hot water output	L/h	257	428	428
Max outlet water temp of heat pump	°C	60	60	60
Max tank water temperature	°C	55	55	55
Circulating water flow	m³/h	2.3	3.8	3.8
Noise	dB(A)	57	58	58
Water pipe connector	mm	G1"		
Ambient condition	°C	-10~46		
Net/Gross weight	kg	94/112	125/133	125/133
Unit dimensions(L×W×H)	mm	1160×510×1430		

The data in the following table are tested under rated conditions as follows:

1. Heating test conditions: ambient air dry bulb temperature 20°C, wet bulb temperature 15°C;
2. Entering water temperature 15°C, leaving water temperature 55°C;
3. All specifications are subject to change without prior notice, please refer to the nameplate.

EVI R410A — 380V ~ 415 60Hz

Model		WFRS-20E4P
Power supply (V / Hz / Ph)		380/60/3
Refrigerant		R410A
Heating capacity	kW	20
Rated power input	kW	4.24
COP	W/W	4.71
Rated hot water output	L/h	428
Heating capacity(-12°C)	kW	10.4
COP(-12°C)	W/W	2.7
Heating capacity(-20°C)	kW	8.6
COP(-20°C)	W/W	2.3
Max outlet water temp of heat pump	°C	65
Max tank water temperature	°C	60
Circulating water flow	m³/h	3.77
Noise	dB(A)	59
Water pipe connector	mm	G1"
Ambient condition	°C	-25~46
Net/Gross weight	kg	130/138
Unit dimensions(L×W×H)	mm	1160×510×1430

The data in the following table are tested under rated conditions as follows:

1. Heating test conditions: ambient air dry bulb temperature 20°C, wet bulb temperature 15°C;
2. Entering water temperature 15°C, leaving water temperature 55°C;
3. All specifications are subject to change without prior notice, please refer to the nameplate.

ENGINEERING APPLICATION DIAGRAM

Diagram 1 — Hot water system

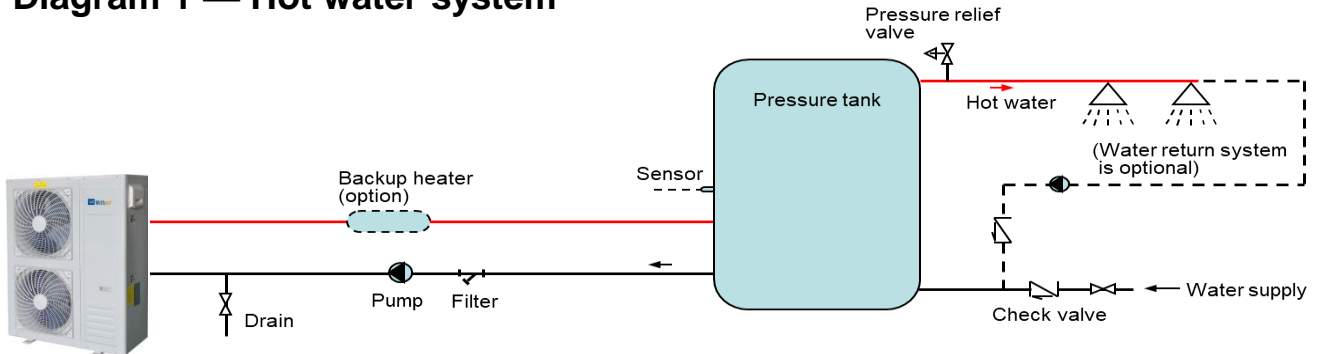

Diagram 2 — Hot water system (with non-pressure tank)

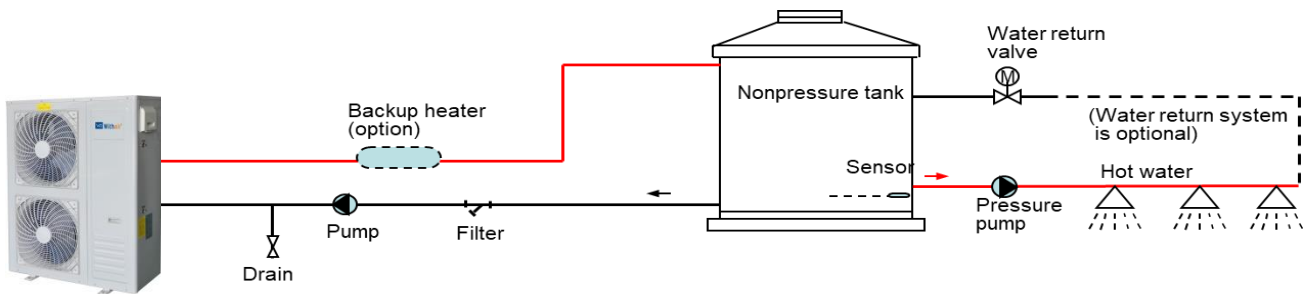

Diagram 3 — Room heating system

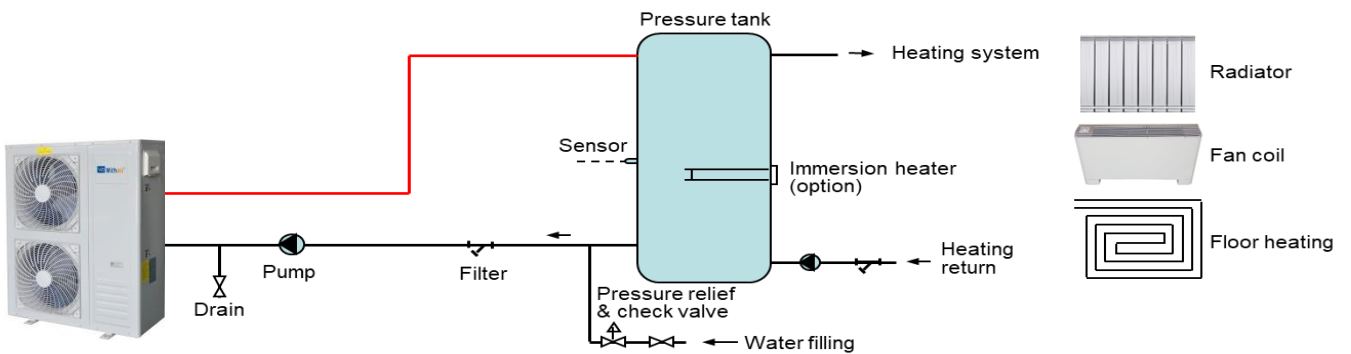
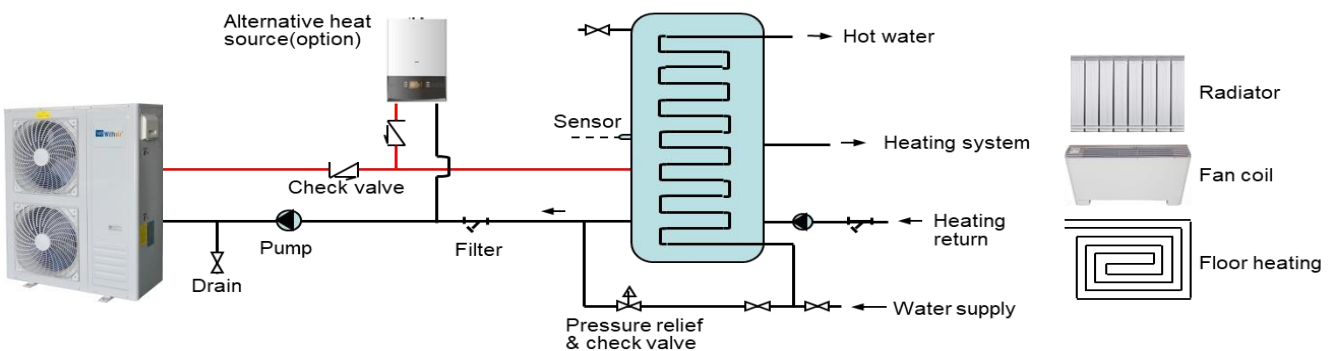

Diagram 4 — Hot water & room heating system



MODULAR COMMERCIAL CIRCULATING HEAT PUMP WATER HEATER



Product Features

01. Applied range: sanitary hot water; floor heating, radiator heating, fan coil heating.
02. Special heat pump compressor.
03. Electronic expansion valve regulates the flow of refrigerant precisely.
04. Air exchanger (Fins-coil) with hydrophilic coating.
05. Water exchanger: tube in tube heat exchanger, Internal spiral design, high thermal efficiency and effective to prevent scaling.
06. Galvanized plate housing, powder coating.
07. Modular control design: units installing combine freely, one controller can control maximum 16 pcs units, and the quantity of running compressors will be auto adjusted according to water temperature changing.
08. Soft start design: compressors start or stop in sequence, first start the one with longer rest.
09. With hot water return control to keep the water warm in supplying pipe.
10. With water replenish control function for non-pressure water tank.
11. Can set the operating time freely (Two stage timing setting).
12. Unit runs or stop automatically according to tank water temperature.
13. Intelligently and automatically judge the frosting degree and accurately defrost.
14. Automatic prevent freezing in the winter.
15. With control of auxiliary heating device (e.g. electric heating).
16. Fault diagnosis and display.
17. High pressure protection, Low pressure protection, compressor discharge temperature protection, water temperature protection, water flow protection, Power phase sequence protection, and other multiple protection.
18. Automatic restart when power supply is restored; Auxiliary heating manual and automatic control; Operation parameter query; Control parameter query and setting; etc.
19. BACnet, RS485 and Modbus communication function as option.

HEAT PUMP MODEL AND SPECIFICATION

R410A — 380 ~ 415V 50Hz

Model		WFRS-20E2M	WFRS-42E2M	WFRS-72E2PM	WFRS-86E2PM
Power supply (V / Hz / Ph)		380~415/50/3			
Refrigerant		R410A			
Heating capacity	kW	20	42	72	86
Rated power input	kW	4.4	9.15	15.75	18.86
COP	W/W	4.55	4.59	4.57	4.56
Rated hot water output	L/h	428	900	1560	1880
Max outlet water temp of heat pump	°C	60	60	60	60
Max tank water temperature	°C	55	55	55	55
Circulating water flow	m ³ /h	3.8	7.9	16.0	19.0
Noise level	dB(A)	58	65	67	70
Water pipe connector	mm	G1"	G1-1/2"	G2"	G2"
Ambient condition	°C	-10~46			
Net/Gross weight	kg	125/133	300/320	860/950	950/1120
Unit dimension (L×W×H)	mm	1160×510×1430	1445×740×1650	2000×1100×1950	2000×1100×1950

The data in the following table are tested under rated conditions as follows:

1. Heating test conditions: ambient air dry bulb temperature 20°C, wet bulb temperature 15°C;
2. Entering water temperature 15°C, leaving water temperature 55°C;
3. All specifications are subject to change without prior notice, please refer to the nameplate.

EVI R410A — 380V ~ 415V 50Hz

Model		WFRS-22E2PM	WFRS-45E2PM	WFRS-76E2PM	WFRS-92E2PM
Power supply (V / Hz / Ph)		380~415/50/3			
Refrigerant		R410A			
Heating capacity	kW	22	45	76	92
Rated power input	kW	4.54	9.18	15.44	18.85
COP	W/W	4.85	4.90	4.92	4.88
Rated hot water output	L/h	471	964	1671	2013
Heating capacity(-12°C)	kW	11.44	23.40	39.52	47.84
COP(-12°C)	W/W	2.72	2.74	2.74	2.75
Heating capacity(-20°C)	kW	9.46	19.35	32.68	39.56
COP(-20°C)	W/W	2.33	2.35	2.36	2.35
Max outlet water temp of heat pump	°C	65	65	65	65
Max tank water temperature	°C	60	60	60	60
Circulating water flow	m ³ /h	4.1	8.5	17.2	20.5
Noise	dB(A)	59	65	68	71
Water pipe connector	mm	G1"	G1-1/2"	G1-1/2"	G1-1/2"
Ambient condition	°C	-25~46			
Net/Gross weight	kg	125/133	300/320	860/950	950/1120
Unit dimension (L×W×H)	mm	1160×510×1430	1445×740×1650	2000×1100×1950	2000×1100×1950

The data in the following table are tested under rated conditions as follows:

1. Heating test conditions: ambient air dry bulb temperature 20°C, wet bulb temperature 15°C;
2. Entering water temperature 15°C, leaving water temperature 55°C;
3. All specifications are subject to change without prior notice, please refer to the nameplate.

HEAT PUMP MODEL AND SPECIFICATION

R410A — 380 ~ 415V 60Hz

Model		WFRS-20E4M	WFRS-42E4M	WFRS-72E4M	WFRS-86E4M
Power supply (V / Hz / Ph)		380/60/3			
Refrigerant		R410A			
Heating capacity	kW	20	42	72	86
Rated power input	kW	4.4	9.15	15.65	18.61
COP	W/W	4.55	4.59	4.60	4.62
Rated hot water output	L/h	428	900	1560	1880
Max outlet water temp of heat pump	°C	60	60	60	60
Max tank water temperature	°C	55	55	55	55
Circulating water flow	m ³ /h	3.8	7.9	16.0	19.0
Noise level	dB(A)	58	65	67	70
Water pipe connector	mm	G1"	G1-1/2"	G2"	G2"
Ambient condition	°C	-10~46			
Net/Gross weight	kg	125/133	300/320	860/950	950/1120
Unit dimension (L×W×H)	mm	1160×510×1430	1445×740×1650	2000×1100×1950	2000×1100×1950

The data in the following table are tested under rated conditions as follows:

1. Heating test conditions: ambient air dry bulb temperature 20°C, wet bulb temperature 15°C;
2. Entering water temperature 15°C, leaving water temperature 55°C;
3. All specifications are subject to change without prior notice, please refer to the nameplate.

EVI R410A — 380V ~ 415V 60Hz

Model		WFRS-20E4PM	WFRS-42E4PM	WFRS-72E4PM	WFRS-86E4PM
Power supply (V / Hz / Ph)		380/60/3			
Refrigerant		R410A			
Heating capacity	kW	20	42	72	86
Rated power input	kW	4.12	8.57	14.75	17.55
COP	W/W	4.85	4.90	4.88	4.90
Rated hot water output	L/h	428	900	1560	1880
Heating capacity(-12°C)	kW	10.4	21.84	37.44	44.72
COP(-12°C)	W/W	2.72	2.74	2.75	2.76
Heating capacity(-20°C)	kW	8.6	18.06	30.96	36.98
COP(-20°C)	W/W	2.33	2.35	2.35	2.37
Max outlet water temp of heat pump	°C	65	65	65	65
Max tank water temperature	°C	60	60	60	60
Circulating water flow	m ³ /h	3.8	7.9	16.0	19.0
Noise	dB(A)	58	65	68	71
Water pipe connector	mm	G1"	G1-1/2"	G2"	G2"
Ambient condition	°C	-25~46			
Net/Gross weight	kg	125/133	300/320	860/950	950/1120
Unit dimension (L×W×H)	mm	1160×510×1430	1445×740×1650	2000×1100×1950	2000×1100×1950

The data in the following table are tested under rated conditions as follows:

1. Heating test conditions: ambient air dry bulb temperature 20°C, wet bulb temperature 15°C;
2. Entering water temperature 15°C, leaving water temperature 55°C;
3. All specifications are subject to change without prior notice, please refer to the nameplate.

ENGINEERING APPLICATION DIAGRAM

Diagram 1 — Hot water system (with pressure tank)

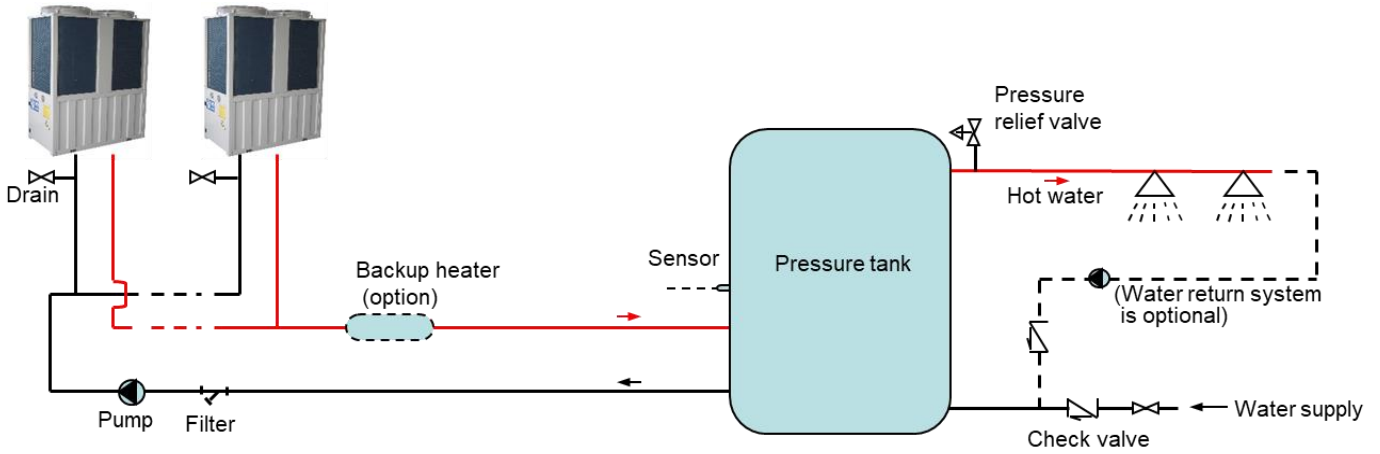

Diagram 2 — Hot water system (with non-pressure tank)

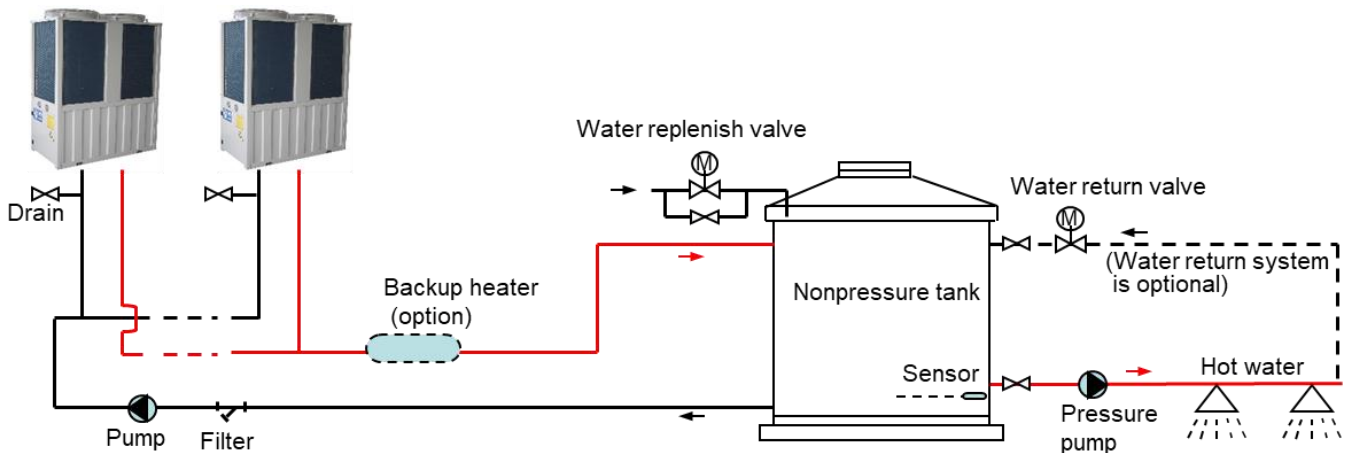
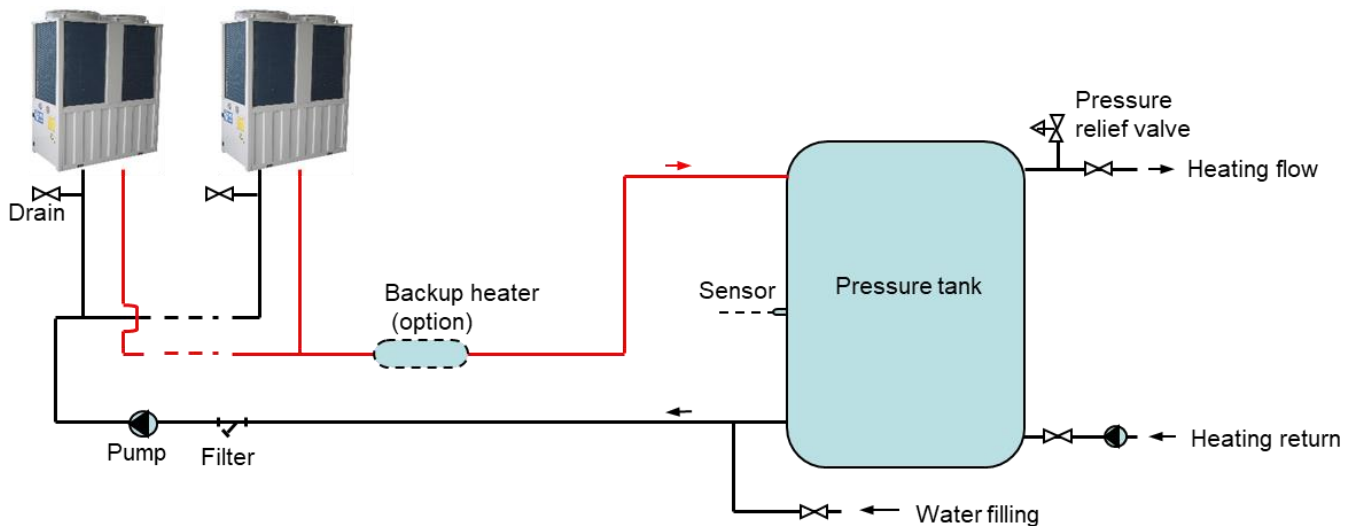

Diagram 3 — Room heating system



ULTRA-HIGH TEMPERATURE HEAT PUMP WATER HEATER (UP TO 90°C)



Withair's high temperature heat pump water heater, using the principle of the heat pump, draws heat from the ambient air through the thermodynamic cycle, then transfers the heat to the condenser through the compressor, and finally recurrently heats the water of the water tank to the required temperature. During the operation of the unit, there is no gas emission, it is environment-friendly and energy-saving. It can not only completely achieve water and electricity separation but eliminate the dangers like flammable, explosive, electric shock, poisoning, etc. that a traditional water heater may have. It adopts modular design, has flexible combination and strong expansion, and can heat all day long, the temperature of the water can be adjusted freely. Commercial hot water heater can be widely applied in the central heat supply of guesthouses, hotels, hospitals, schools, bathing centers and district and the factory hot water.

The projects include a industrial hot water project, hotel hot water project, school hot water project, sauna hot water project and so on. Outlet hot water temperature can set from 55°C~90°C as user requirement, so it is widely using home radiator heating by 65°C, 75°C, 80°C and 90°C hot water for industry heating use --like a factory, textile, printing, and dying, military industry, steam line, ironing, explosive, medicine high-temperature sterilization line, oil drilling and so on. Suitable for high temperature hot water project and cold area heating project.

Withair® high temperature heat pump mainly uses electricity, but electricity is only used to drive heat pump system to absorb heat from outside environment. And then the heat is released to heat. Unlike conventional electric heaters, which directly use one-degree electricity to form 860 large calories, the experiment proves that the heat from the same one-degree electricity absorbed from outside for the heat pump system is four bits of 860 calories, so the electricity used is only 1/4 of the electric heater.

A simple analogy: a heat pump can use an electric energy to absorb 2-3 free heat from the environment, then use this heat energy for heating, and the electrical energy is also used for heating. The experiment will eventually make the heat efficiency up to 300-500%.

The general heating methods are directly heated by energy, the energy efficiency of the electric heater is 95%, and the natural gas is about 80%. The heat pump water heater uses electricity to drive the compressor, instead of being used directly for heating. The heat comes from the environment.

Saving energy means saving money, it saves the operating cost of 3/4 compared with electric heating and oil furnace; saves 2/3 running cost compared with the gas heater; saves a large labor cost and environmental protection compared with coal. Even if compared with the solar energy, it can save the running cost of 1/3, and use the heat of valley electricity to shift the electricity from the peak periods to off-peak periods, so the run cost is saved again and again.

The scope of application: high temperature heat pump water heater can meet the heating demand of agricultural and sideline products processing industry, beverage processing industry, electroplating dyeing industry, textile printing and dyeing industry, drying industry, disinfection, oil drilling and so on.

SCHEMATIC DIAGRAM

<p>DHW 55°C - 90°C</p>	<p>Power supply 380V/50 Hz</p>	<p>Air To Water Heating Source -10°C ~ 45°C</p>	<p>Inverter Driver Panel HITACHI</p>	<p>Refrigerant ECO Friendly R410A+R134a</p>	<p>MAX Outlet 90°C</p>
----------------------------	------------------------------------	---	--	---	----------------------------

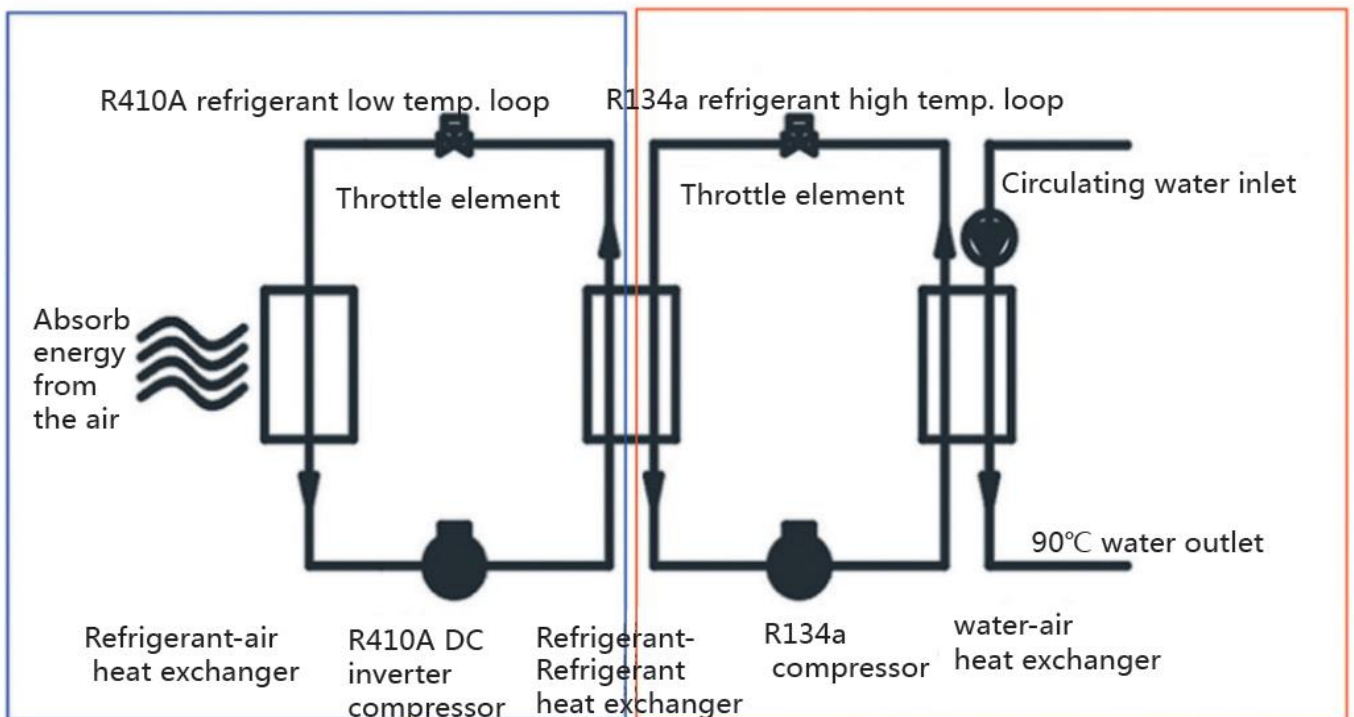

Product Features

01. The flexible scroll type high-temperature compressor;
02. Intelligent digital smart throttle technology;
03. High-temperature superconducting heat system;
04. WIFI remote control for option
05. Condensing pressure balance valve;
06. Monobloc design , inside built-in water pump for option;
07. Special high-temperature compressor to sure running stable;
08. Environmental protection type high-temperature heat carrier;
09. Auto high & low pressure sensor to protection, Auto defrost , auto power-off memory;
10. The design is compact and reasonable, with perfect safety protection and low noise;
11. The maximum temperature up to 80°C, which can meet the needs of different applications.
12. Fault diagnosis and display.
13. High pressure protection, Low pressure protection, compressor discharge temperature protection, water temperature protection, water flow protection, Power phase sequence protection, and other multiple protection.
14. Automatic restart when power supply is restored; Auxiliary heating manual and automatic control; Operation parameter query; Control parameter query and setting; etc.
15. BACnet, RS485 and Modbus communication function as option.

SYSTEM DIAGRAM

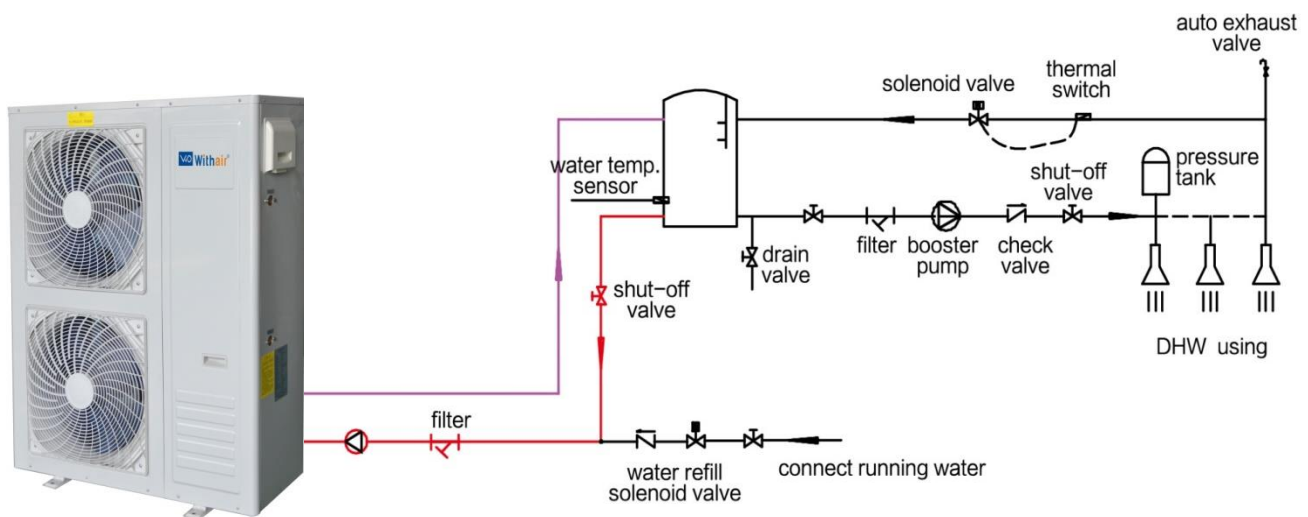

HEAT PUMP MODEL AND SPECIFICATION

— Up to 80°C hot water production

R134a — 380 ~ 415V 50Hz

Model No.		W01R1-12HT	W01R1-20HT	W01R1-35HT
Heating capacity	kW	12	20	35
Rated input power	kW	2.7	4.5	7.82
Rated input current	A	5.2	8.0	8.0
Maximum input power	kW	3.5	5.98	11.1
Maximum input current	A	6.6	10.7	18.6
COP	W/W	4.44	4.44	4.48
Electric shock protection grade		I		
Waterproof grade		IPX4		
Ambient temperature	°C	-10 ~ 46		
Power supply	V/Ph/Hz	380~415/3/ 50	380~415/3/ 50	380~415/3/ 50
Hot water temperature	°C	30 ~ 80		
Hot water flow rate	L/h	265	416	780
Inlet/outlet pipe size	In	1"	1"	1-1/2"
Water side pressure drop	kPa	≤70		
Water pump flow rate	m³/h	2.5	4.5	6.6
Discharge side maximum pressure	Mpa	4.6		
Suction side minimum pressure	Mpa	0.05MPa		
Compressor		Rotary	Scroll	Scroll
Refrigerant		R134a	R134a	R134a
Heat exchanger type		High efficiency tube in shell heat exchanger		
Noise level	dB(A)	55	60	63
Unit dimension (LWXH)	mm	690×690×850	1100×490×1265	1406×765×1050
Package dimension (LWXH)	mm	750×750×900	1180×570×1375	1500×830×1200
Weight (NW/GW)	kg	110/125	108/126	295/325

The data in the following table are tested under rated conditions as follows:

1. Heating test conditions: ambient air dry bulb temperature 20°C, wet bulb temperature 15°C;
2. Entering water temperature 15°C, leaving water temperature 80°C;
3. All specifications are subject to change without prior notice, please refer to the nameplate.

HEAT PUMP MODEL AND SPECIFICATION

— Up to 90°C hot water production

R410 & R134a — 380 ~ 415V 50Hz

Model		W01R1-20IHT	W01R1-40IHT	W01R1-80IHT
Power supply	V/Ph/Hz	380/3/50		
Rated heating capacity	kW	20.6	40.9	81.2
Rated heating input power	kW	6.3	12.6	25.2
COP	w/w	3.27	3.25	3.23
Maximum input power	kW	12.6	25.2	50.4
Maximum input current	A	20.5	41	82
Hot-water yield	L/h	236	465	932
Refrigerant		First stage: R410A, second stage: R134a		
Hot water temperature range	°C	30 ~ 90		
Working ambient temperature	°C	-25 ~ 46		
Compressor	First stage	MITSHUBISHI R410A DC inverter compressor		
	second stage	R134a high temperature compressor		
Controller system		Smart full LCD display controller		
Refrigerant side heat exchanger		High efficiency 316L coupled plate heat exchanger		
Water side heat exchanger		High efficiency tank shell and tube heat exchanger		
Throttling method		Electronic expansion valve		
Pressure device		Built-in high and low pressure sensor		
Electronic components		Schneider AC contactor		
System switching valve		High temperature solenoid valve		
Noise level	dB(A)	57	65	67
Net weight	kg	150/180	420/450	850/890
Water connection pipe	inch	Rc1"	Rc1-1/2"	Rc2-1/2"
Product dimension (L*W*H)	mm	1120×550×1600	1050×900×1920	1820×1050×1960

The data in the following table are tested under rated conditions as follows:

1. Heating test conditions: ambient air dry bulb temperature 20°C, wet bulb temperature 15°C;
2. Entering water temperature 15°C, leaving water temperature 90°C;
3. All specifications are subject to change without prior notice, please refer to the nameplate.

HEAT PUMP MODEL AND SPECIFICATION

— Up to 90°C hot water production

R410 & R134a — 380 ~ 415V 60Hz

Model		W01R1-20IHT2	W01R1-40IHT2	W01R1-80IHT2
Power supply	V/Ph/Hz	380~415/3/60		
Rated heating capacity	kW	20.6	40.9	81.2
Rated heating input power	kW	6.3	12.6	25.2
COP	w/w	3.27	3.25	3.23
Maximum input power	kW	12.6	25.2	50.4
Maximum input current	A	20.5	41	82
Hot-water yield	L/h	236	465	932
Refrigerant		First stage: R410A, second stage: R134a		
Hot water temperature range	°C	30 ~ 90		
Working ambient temperature	°C	-25 ~ 46		
Compressor	First stage	MITSHUBISHI R410A DC inverter compressor		
	second stage	R134a high temperature compressor		
Controller system		Smart full LCD display controller		
Refrigerant side heat exchanger		High efficiency 316L coupled plate heat exchanger		
Water side heat exchanger		High efficiency tank shell and tube heat exchanger		
Throttling method		Electronic expansion valve		
Pressure device		Built-in high and low pressure sensor		
Electronic components		Schneider AC contactor		
System switching valve		High temperature solenoid valve		
Noise level	dB(A)	57	65	67
Net weight	kg	150/180	420/450	850/890
Water connection pipe	inch	Rc1"	Rc1-1/2"	Rc2-1/2"
Product dimension (L*W*H)	mm	1120×550×1600	1050×900×1920	1820×1050×1960

The data in the following table are tested under rated conditions as follows:

1. Heating test conditions: ambient air dry bulb temperature 20°C, wet bulb temperature 15°C;
2. Entering water temperature 15°C, leaving water temperature 90°C;
3. All specifications are subject to change without prior notice, please refer to the nameplate.

HEATING(COOLING) BUFFER TANK



Specification

Tank model		SN40	SN100	SN150	SN200	SN300
Volume	L	40	100	150	200	300
Heat pump inlet/outlet connector	mm	DN20(G3/4")	DN25(G1")	DN40(G1-1/2")	DN40(G1-1/2")	DN50(G2")
Heating supply/return connector	mm	DN20(G3/4")	DN25(G1")	DN40(G1-1/2")	DN40(G1-1/2")	DN50(G2")
Water filling connector	mm	DN20(G3/4")	DN20(G3/4")	DN20(G3/4")	DN20(G3/4")	DN20(G3/4")
Drain connector	mm	DN15(G1/2")	DN15(G1/2")	DN15(G1/2")	DN15(G1/2")	DN15(G1/2")
Exhaust valve		DN20(G3/4")	DN20(G3/4")	DN20(G3/4")	DN20(G3/4")	DN20(G3/4")
Unit dimension (D×H)	mm	Ø420×585	Ø480×1115	Ø480×1385	Ø520×1535	Ø580×1782
Packing dimension (L×W×H)	mm	545×545×1531	595×595×1628	545×545×1531	595×595×1628	635×635×1847
Net/Gross weight	kg	30/34	35/41	30/34	35/41	53/60
Inner tank material		Stainless steel 304				
Insulation thickness	mm	50				
Out case		Color galvanized steel sheet				

* Auxiliary electric heating as option

The Application Diagram

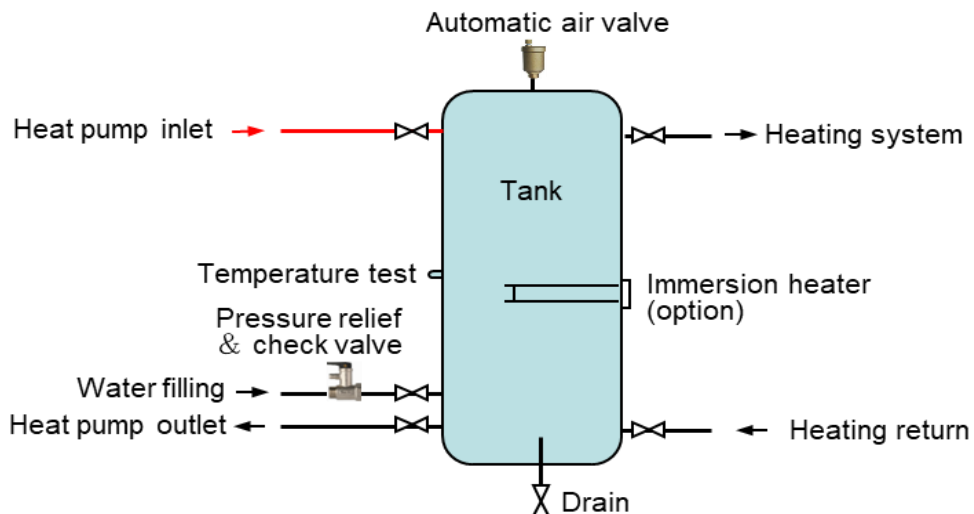

DOMESTIC WATER COOLER



Product Features

01. Applied range: In tropical climates, cool the hot tap water.
02. Special compressor: Suitable for high temperature environment.
03. Electric expansion valve regulates the flow of refrigerant precisely.
04. Air exchanger (Fins-coil) with hydrophilic coating.
05. LCD display wire controller.
06. Can set the operating time freely (Two stage timing setting).
07. Unit runs or stop automatically according to water temperature.
08. Failure diagnosis and display.
09. High pressure protection, Low pressure protection, compressor discharge temperature protection, water temperature protection, water flow protection, Power phase sequence protection, and other multiple protection.
10. Automatic restart when power supply is restored; Valley power economic operation; Operation parameter query; Control parameter query and setting; etc.
11. Water tank:
 - The inner tank material is stainless steel 304.
 - The heating water exchanger is installed in inner tank, high heat exchange efficiency. The material of heat exchange coil is food grade stainless steel 316L.
 - Insulation layer is 50mm.

HEAT PUMP MODEL AND SPECIFICATION

R410A ——220 ~ 240V 50Hz

Outdoor unit model		WFLS-3E1W
Power supply (V / Hz / Ph)		220-240 / 50 / 1
Refrigerant		R410A
Cooling capacity	kW	3
Rated power input	kW	0.9
COP	W/W	3.30
Rated cool water output	L/h	128
Water temperature range	℃	15~40
Noise	dB(A)	50
Net/Gross weight	kg	28/32
Unit dimension (L×W×H)	mm	700×255×545
Packing dimension (L×W×H)	mm	825×300×640
Ambient condition	℃	30~52
Matching tank model		FX100-1 or FX150-1 or FX200-1
Main accessories		Connecting pipe(Ø9.52/Ø6.35mm), Power line,etc

The data in the following table are tested under rated conditions as follows:

1. Cooling test conditions: ambient air dry bulb temperature 46℃, wet bulb temperature 24℃;
2. Entering water temperature 40℃, leaving water temperature 20℃;
3. All specifications are subject to change without prior notice, please refer to the nameplate.

Tank model		FX100-1	FX150-1	FX200-1
Volume	L	100	150	200
Cold/hot water pipe connector	mm	G1/2"		
Drain connector	mm	G1/2"		
Fluorine pipe connector	in	5/8", 7/16"	5/8", 7/16"	5/8", 7/16"
Net/Gross weight	kg	26/30	31/35	36/42
Unit dimension (D×H)	mm	Ø480×1000	Ø480×1385	Ø520×1535
Packing dimension (L×W×H)	mm	545×545×1146	545×545×1531	595×595×1628

ENGINEERING APPLICATION DIAGRAM

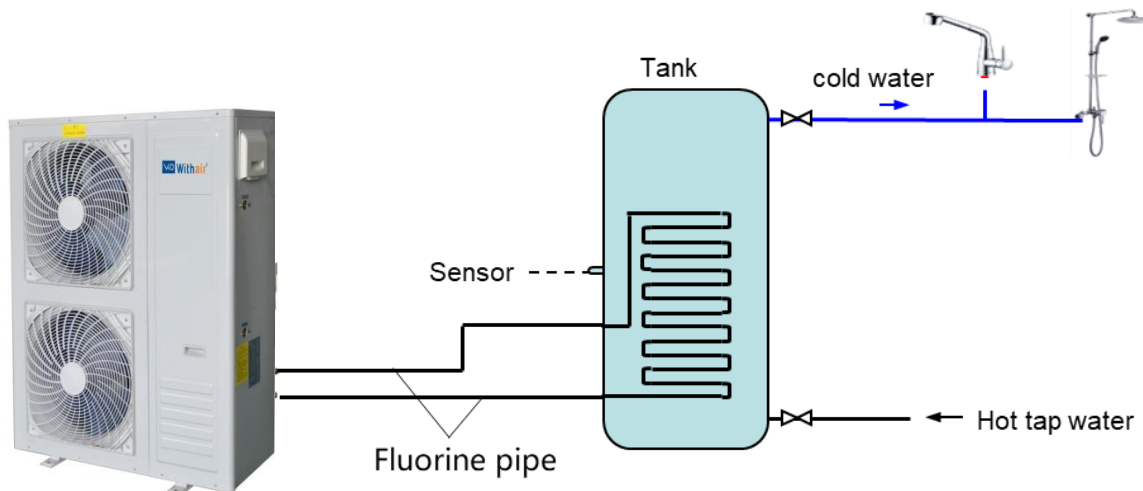

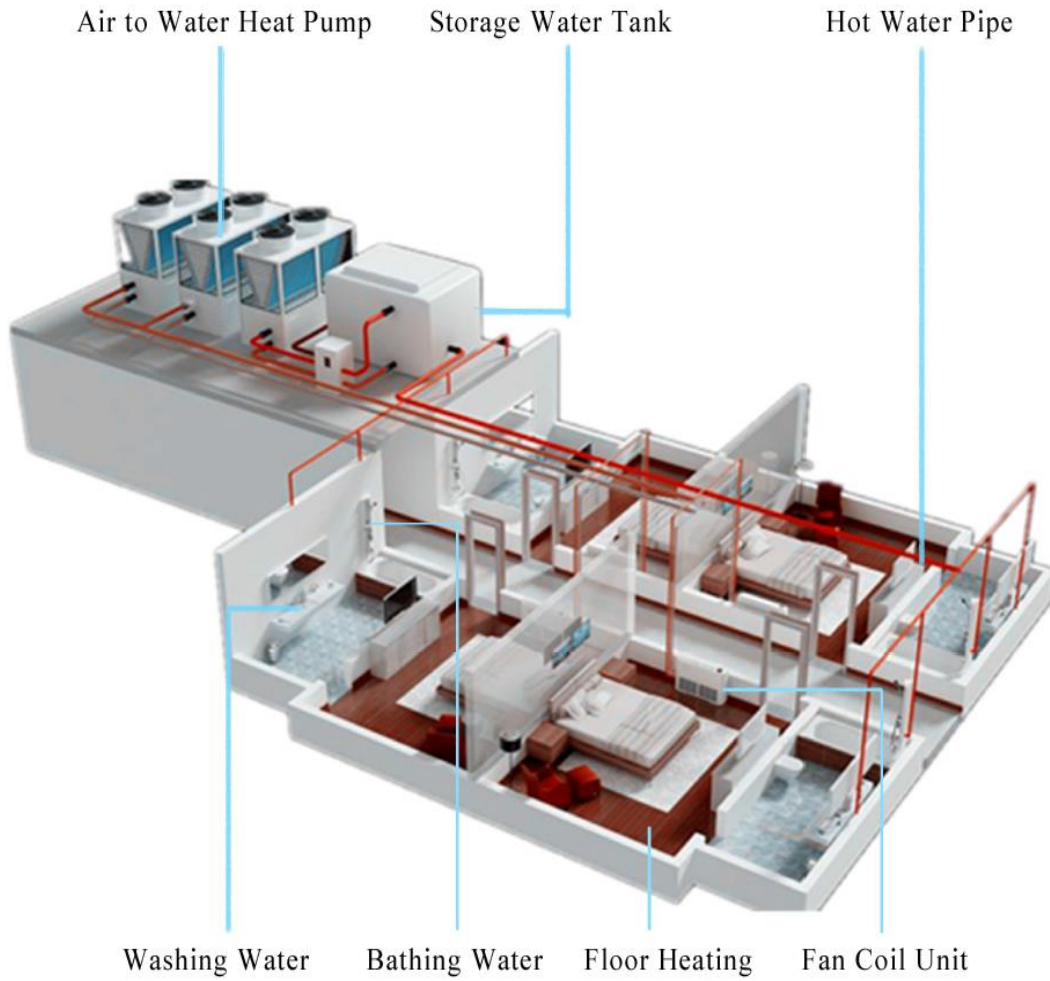

☆ Installation location

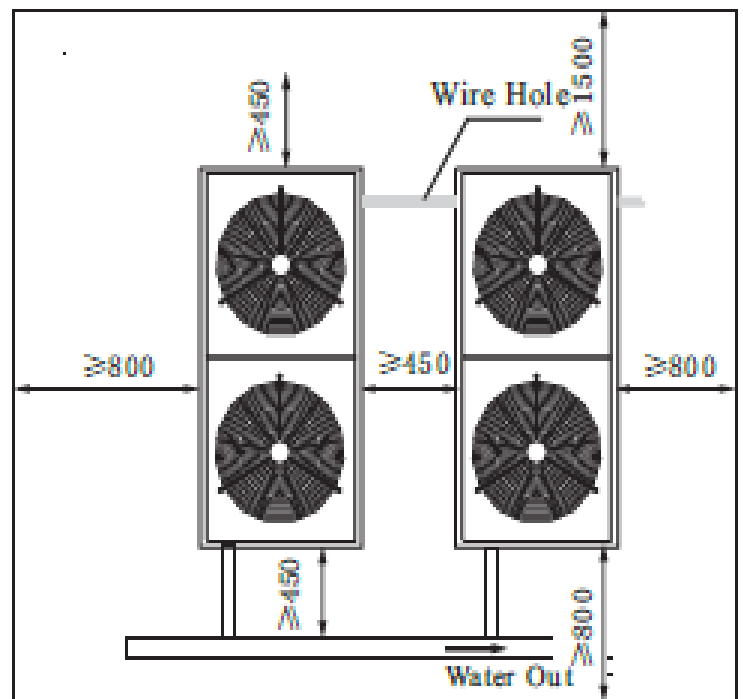
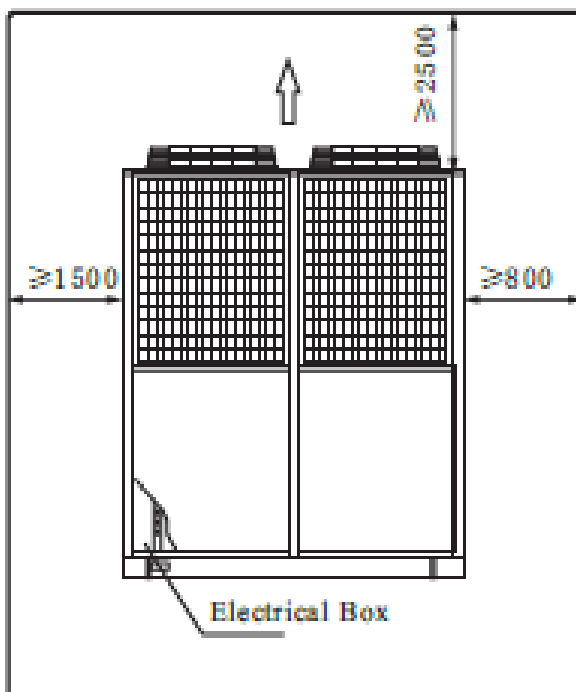
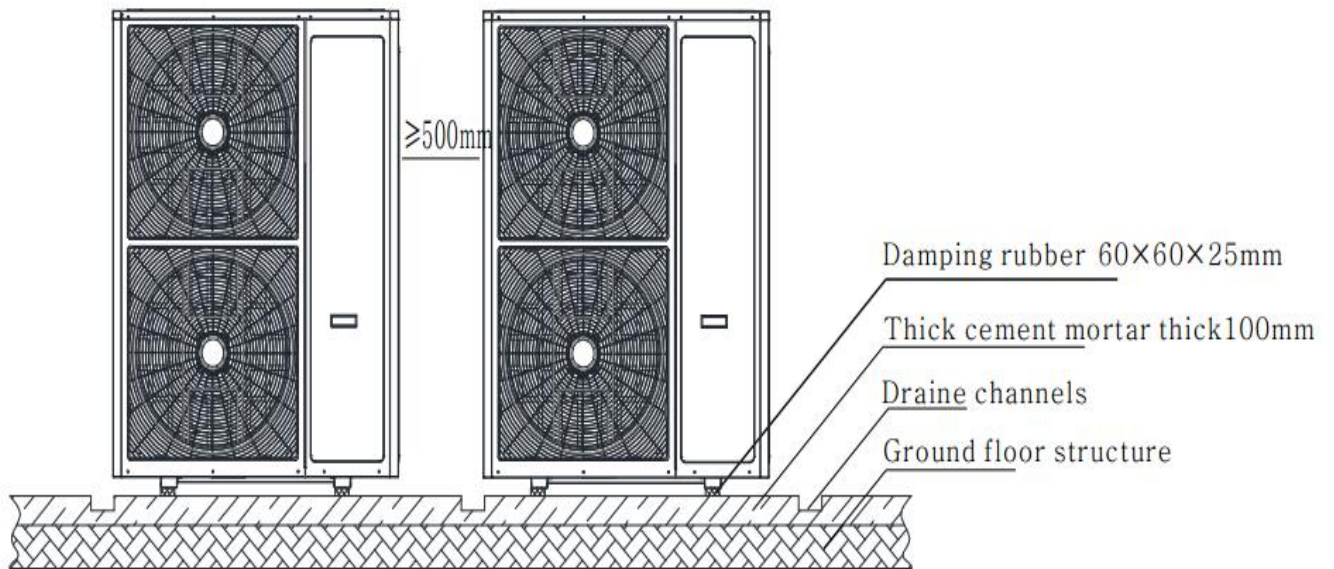

Notes:

- A). Near to in the indoor terminal, reducing water system resistance losses.
- B). Near to the power and convenient for wiring connection.
- C). Near to the water source and convenient for installation.
- D). Strong enough to support unit weight and running vibration.
- E). Enough space in order to install, repair, maintenance.
- F). Water source not near to the dirty and corrosive fluid, keep pure water, water chlorinity does not exceed 25ppm

Assembly and Test

The unit shall be completely factory assembled, pre-charged and wired. Complete unit must be test operated at factory prior to shipment.

Refrigerant System

Each refrigerant circuit shall include a high-efficiency scroll compressor, high pressure control, low pressure control, TXV, and refrigerant pressure gauge connections.

Electrical

The unit shall have 24-volt electromechanical controls and include compressor contactors, 24-volt transformer, terminal strip, compressor staggered start, fault lockout circuit, compressor anti-short cycle, low pressure switch by-pass timer, LED for compressor ON/OFF and fault status, and the necessary relays for compressor and reversing valve operation.

The reversing valve is energized in the cooling mode.

Installation Requirements

- (1) Be sure to take the base preparation and structure into consideration seriously during installation, particularly on rooftop installations in order to avoid noise and vibration. Consulting the building designer before conducting installation is recommended.
- (2) A drainage ditch should surround the base to ensure dewatering occurs
- (3) Anti-vibration pad is to be placed between the base frame and foundation in order to avoid vibrations and unnecessary noise, and make sure the unit is horizontal during installation.
- (4) The maximum altitude difference (levelness) should be within 3mm for the chiller base.
- (5) The base should be raised by 100mm.
- (6) The installation base of the unit must be concrete or steel structure, which can bear the running weight of the machine. The top should be horizontal. It is ideal to prepare a drainage ditch around installation base.
- (7) Put the steel plate and anti-vibration pad in the correct position. Finish the installation of the unit and the foundation bolt before secondary concreting. The foundation bolt should protrude 100mm.
- (8) Spring isolators are specified on the sales order as an option.

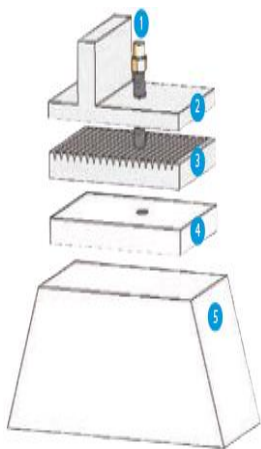

Typical Isolation structure

- 1 Anchor Bolt
- 2 Chiller Frame Base
- 3 Rubber Pad
- 4 Steel Base Plate
- 5 Concrete Base

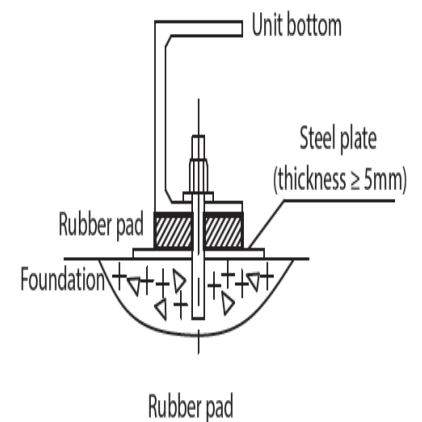
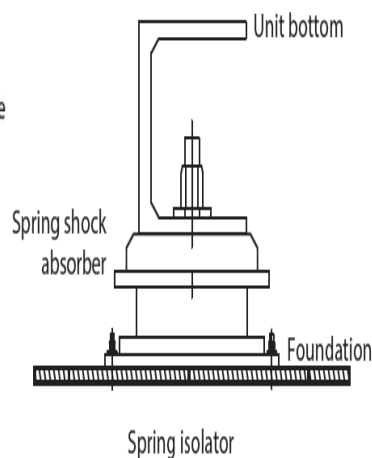

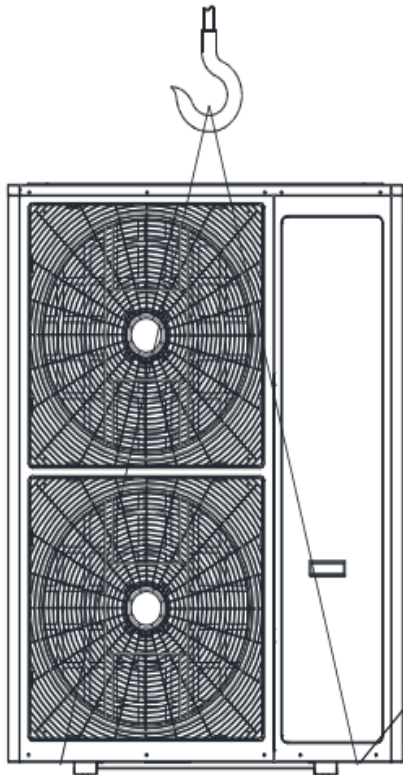

Hoisting schematic

To prevent the unit surface scratches, deformation, it should be at least 50 mm thick mat of wood, cloth or cardboard between the place of unit and Sling contact points. When lifting, do not stand any person under the unit.

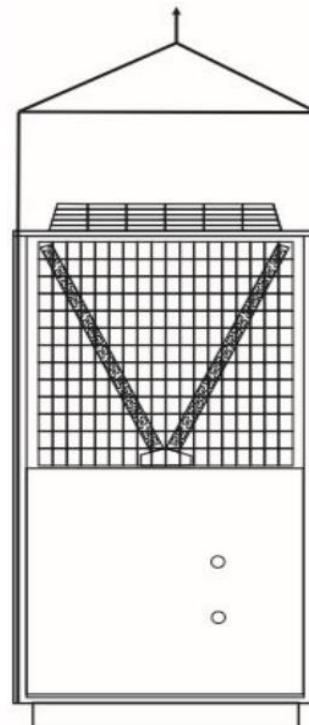
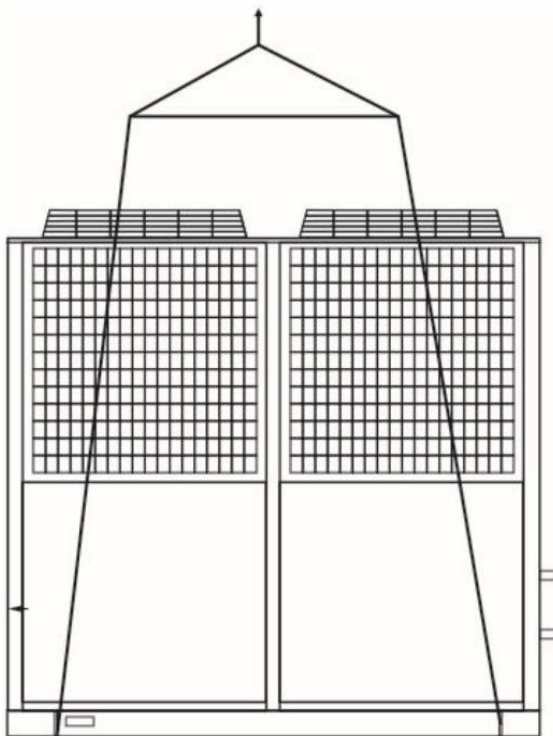

1. The preparation

- 1) After arriving the installation site, check all the items of the unit carefully according to the packing list if there are damage, lack of parts or damage during transport, notify the sales department.
- 2) The user must provide a rigid non-deforming foundation or concrete footings, based on the size of the unit four positioning hole; the foundation of the unit can also be framework structure, framework should be placed on main beam or column, and be capable of bearing the weight 150% heavier than the unit. The horizontal level should have no slope.
- 3) For easy handling, users should use the crane, the machine should properly protected by soft material on the point of force applied, and also be in balanced status during handling to avoid possible damage.
- 4) Choose the Installation Place
Units can be installed indoor or outdoor, should consider the following factors:
 - a) Installation place should be capable of bearing the weight 150% heavier than the unit. The horizontal level should have no slope.
 - b) Should keep enough space surrounding and on the top of the machine for access of maintenance.
 - c) Should have drain in the surrounding of the machine for release the water for seasonal stop of machine.
- 5) Foundation reference
 - a) The foundation should be concreted structure or frame of steel, with a plane surface
 - b) 10-20mm isolator for shock absorption should be placed between the unit and foundation.
 - c) Foundation design can based on the machine net weight.
 - d) Fix the unit with $\phi 16$ foundation bolt
 - e) foundation diagram

2. Maintenance

First maintenance before seasonal running:

1. Check whether the wiring is loose, breakage before operation.
2. Check whether there is gas leakage
3. Check whether there are crack, flat, blockage and tilt of exhaust pipe
4. Check and clean the filter
5. Ensure water system without fracture, jam, etc.

Operation after using season is over

1. Stop running and switch off the unit, cut off the power.
2. Let out the water in the system in winter for cooling model so as not to freeze to damage.
Unit using in winter shall be powered on always so as to run the anti-freeze function

Benefits At A Glance

Withair® designed the complete line of Water to Water Heat Pumps for high efficiency, individually-zoned comfort control in offices, schools, assisted living facilities, manufacturing facilities and other commercial buildings. Our reputation for outstanding reliability and quiet operation has been reinforced in thousands of successful installations.

Using feedback from building owners, consulting engineers, contractors and service engineers, we designed the latest version Water Source Heat Pumps to give you maximum flexibility to design, install, operate and maintain the ideal water source heat pump system for your building project. And we incorporated non-ozone depleting R-410A refrigerant, which—along with high Energy Efficiency Ratios (EER's)—helps preserve our environment and precious energy resources.

For Building Owners and Managers

- Quiet operation
- Easy to maintain
- Reliable operation
- Reduces operating expenses
- Environmentally sound refrigerant
- Building automation system compatible

For Consulting Engineers

- HFC refrigerants
- High-efficiency optimization
- Ideal for replacement projects
- Compliant local code requirements
- Quick response technical support services

For Contractors

- 100% run-tested
- Compact footprint
- Diagnostic controls
- Easy to break down
- Ideal for replacement
- Reliable performance
- Reduces installation expenses



Premium manufacturer in HVACR products
for Heating, Cooling and Indoor Air Quality.

Learn more at www.withair.cn or follow us info@withair.cn

About Withair ®

Withair® is the premium manufacturer in sustainable energy solutions supplying HVACR products & services for heating, cooling, hot water, indoor air quality, industrial refrigeration, and heat recovery that reflect today's demand for sustainable construction, comfortable indoor climate and industrial cooling & heating process application.

© 2022 Withair® All rights reserved.

Withair® reserves the right to introduce at any time whatever modifications deemed necessary for improving the product, The technical data in this document are not binding.